

LI-2B Installation Manual



ARCO Pty. Ltd.

LI-2B Intelligent Gate Controller

Installation/Owners Manual

Please do not commence installation until you have read this instruction book.

LI-2B Installation Manual

Contents:

Introduction

Installation Options:

Standard Installation

Installation Procedure

Side Mount Installation

Restricted Side Room Installation

Out Swing Installation

Control Board & Settings:

Auto Close

Overloads

Anti-Clash leaf delay

Solar Wiring Detail

Options:

Push Button (PB)

Electric Lock (EL)

Photoelectric Safety (PE)

Troubleshooting

Trouble Shooting

LI-2B Installation Manual

Dear Installer/Owner

Congratulations on your purchase of the Australian Made Arco Pty. Ltd. Automatic Gate Operator. The LI-2B gate operator is a breeze to install. It has been researched, designed and manufactured by Arco Pty. Ltd. to be a reliable operator with almost non-existent maintenance required.

To save you time and make installation easier, the LI-2B has a pre-wired control circuit board and placed it under the cover with motor/gears etc. This means that you do not have to spend time wiring up to a separate control box.

Circuitry for most options is already included. You simply have to connect up the external devices. No extra boxes or cables are required.

The design features in the LI-2B gate operator will save you hours on site and the installation will be neat and tidy.

Apart from the physical attributes the control circuit has some powerful operating features. These can be adjusted on-site without modification to suit a range of situations.

This manual should answer most of your questions regarding the installation and operating of the LI-2B gate operator. If further information is required, please contact us.

The Arco Pty. Ltd. LI-2B gate operator can be purchased as a single gate operator (primary), which comes complete with the Logic Control Circuit board and can be installed on either the left or right hand side. The dual set includes the above as well as a secondary (slave) operator that does not have logic control.

LI-2B Installation Manual

Introduction

The Arco Pty. Ltd. LI-2B automatic gate operator is an electronically controlled automatic gate operator for swing gates. The LI-2B has a range of features that are built in and some options are also available.

The LI-2B intelligent Gate operator can be used in a variety of situations.

- 240 Volt AC or Solar Power or 12 Volt AC/DC
- Inward or Outward swinging gates
- Restricted Side Room
- Single gate or a gate pair
- Where a gate is required to swing 90 degree and up to 130 degrees

A powerful control system gives the flexibility to change some important characteristics of the operation which include

- Automatic Close
- Sensitivity to obstacles

The control system also allows for the addition of the following options

- Electric Lock
- Photoelectric cells (240 volt only)
- Operation with a wide range of devices

For all its sophistication the LI-2B gate operator is extremely reliable and its robust construction ensures a long trouble free life.

Arco Pty. Ltd. has extensively tested the LI-2B gate operator. It has undergone rigorous factory load testing and has been passed as ready for site installation.

Please ensure that you read these instructions fully and any other instructions supplied then simply follow the step-by-step instructions.

LI-2B Installation Manual

The LI-2B gate operators are suitable for gates that are correctly hinged and operate smoothly and evenly both before and after the LI-2B gate operator is fitted.

The LI-2B gate operators are suitable for and guaranteed when the following conditions are met.

The LI-2B gate drive system will drive a variety of gate styles, sizes and weights. Suitability is dependant on the quality of hinging and the ongoing force required at ONE metre from the hinge centre-point to open and close the gate. 15kg is the acceptable maximum for gates opening IN (Pull) and 7.5kg for gates opening OUT (Push)

Do not connect to any 240-volt power, solar panel or battery if you do not understand any of the instructions or have any doubts. Please call, fax or email us re your concerns BEFORE you apply power to the unit or you may void your warranty.

DO NOT connect the RED spade terminal to the battery until you are ready to set the Limit Switches. The RED spade terminal is supplied disabled* from the battery. (* i.e. Not connected to the battery)

Important

- All power (240 volt/battery/solar panel) MUST be disconnected before moving Logic Controller (circuit board) to change battery.
- Correct use of a SURFACE insecticide spray** is advised to deter insects from causing damage to the electronics.

** To avoid loss of warranty – DO NOT SPRAY OR ALLOW ANY LIQUIDS ONTO ANY ELECTRONIC CIRCUITRY.

LI-2B Installation Manual

Installation

Standard Installation

A “Standard Installation” is one where the gate(s) open by swinging INWARDS towards the motor housing.

The gate hinge should be no more than 200mm from the rear of the pier/post. Side room of 350mm is required to accommodate the swing of the arms.

Refer to Pages 10 & 11 if there is restricted side room (See figure 1)

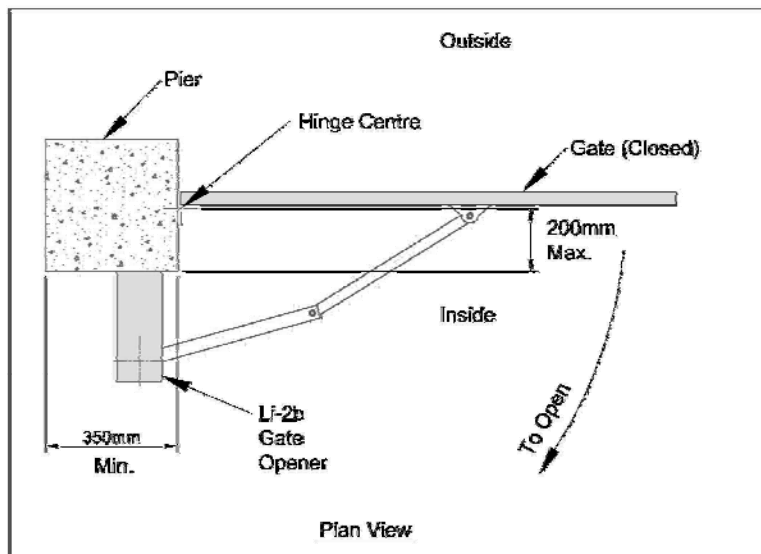

Figure 1: Standard installation.

Installation Procedure

1. Ensure that the gates swing freely and that all existing latches/pad-bolts/chains etc are disabled or removed from the gate and gate posts.
2. When using a 240-volt unit, The Master operator (the one containing the circuit board) should be fitted to the gatepost nearest the power supply. Remove the cover(s) from the operator to access the slotted fixing holes in the rear of the chassis. Bend the tabs out and bend them back against the rear of the chassis, in this position they act as a spacer allowing clearance for the cover(s). NOTE: Do not remove these tabs – just bend them out and fold them to the back unless you are using the OPTIONAL mounting plate.
3. Position each unit on the gate-post{s} approximately 50mm from the edge of the pier/post. The vertical position is found by locating the gate bracket. The gate bracket is best placed where there is adequate fixing on the gate and movement of the arms is unrestricted (See Figure 2). The gate operator may now be bolted in place.

LI-2B Installation Manual

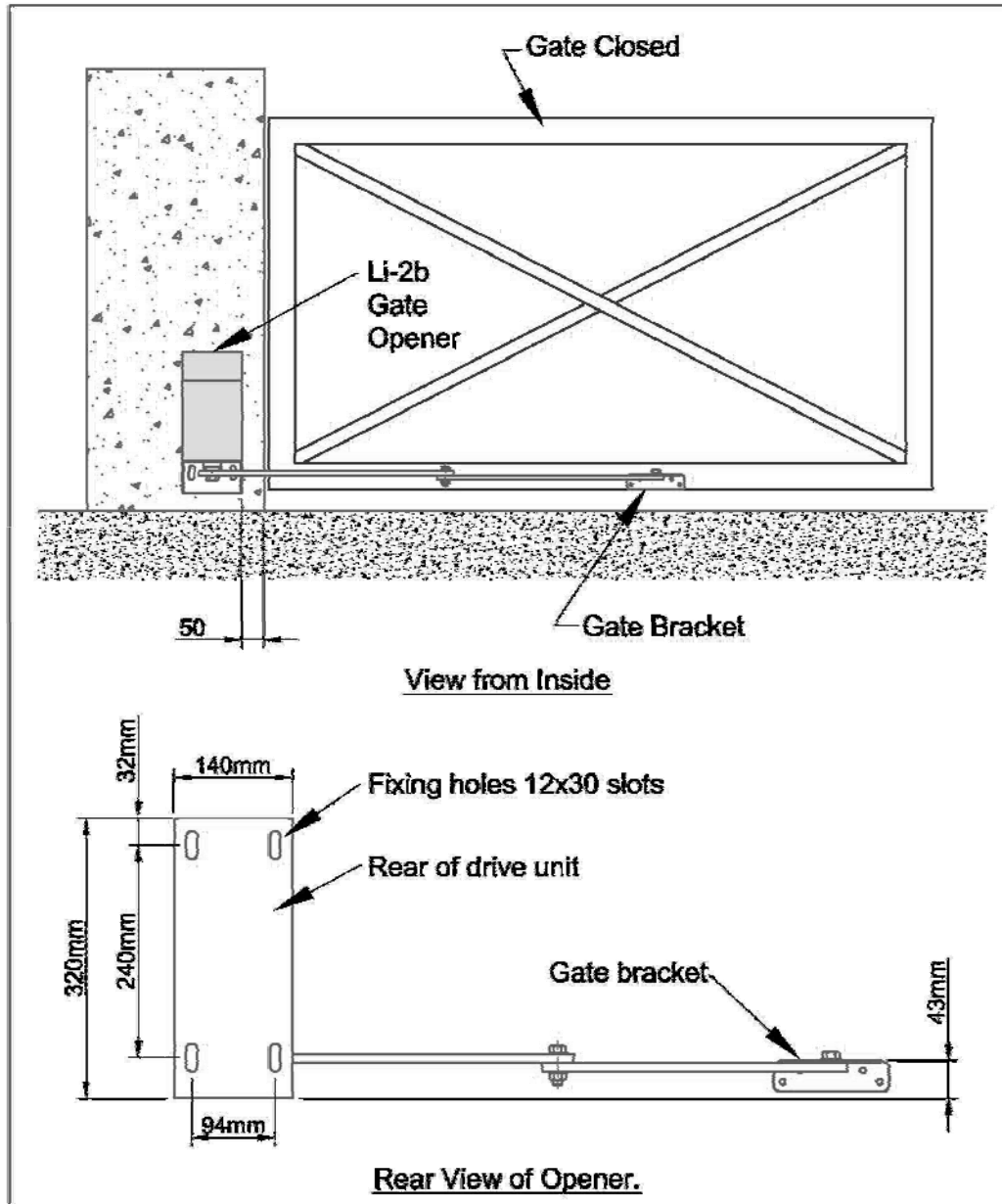

Figure 2: Position of operator.

LI-2B Installation Manual

- If you have a pair of gates then connect the slave to the Master Unit with 2 core Flex/Cable (Max load 8 Amp at 12 Volts) (See Figure 3). The LI-2B operators are set in the factory for a "Standard Installation" with the Master placed on the LEFT HAND SIDE (From the inside looking out). If the Master has to be located on the right then the motor wires need to be reversed. To accomplish this, locate the connection blocks for each motor on the Circuit Board. Swap the BROWN and BLUE wires for Motor 1 and Motor 2 (See Figure 3)

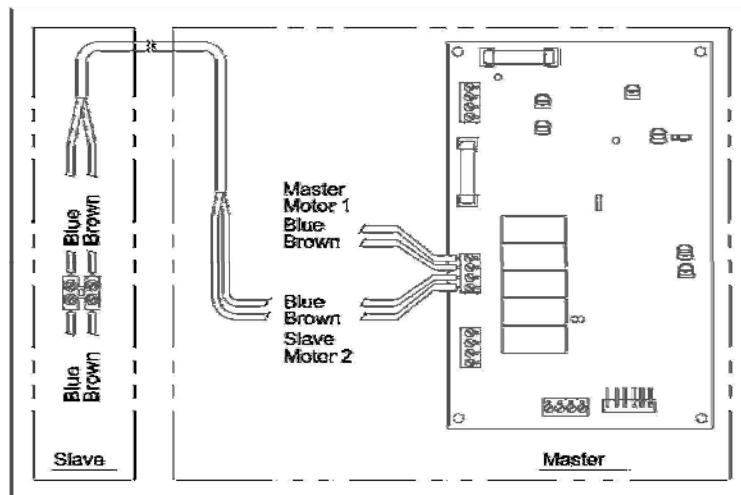

Figure 3: Master-slave connections.

- The gate bracket should be positioned so the arms are ALMOST in a straight line when the gates are closed (See figure 4). To check the location of the gate brackets, first disengage the Main arm from the drive shaft (using the spanner provided, unscrew the bolt until the arm swings freely) THEN CLAMP THE GATE BRACKET IN POSITION. Open and close the gate to ensure the gate bracket is appropriately located.

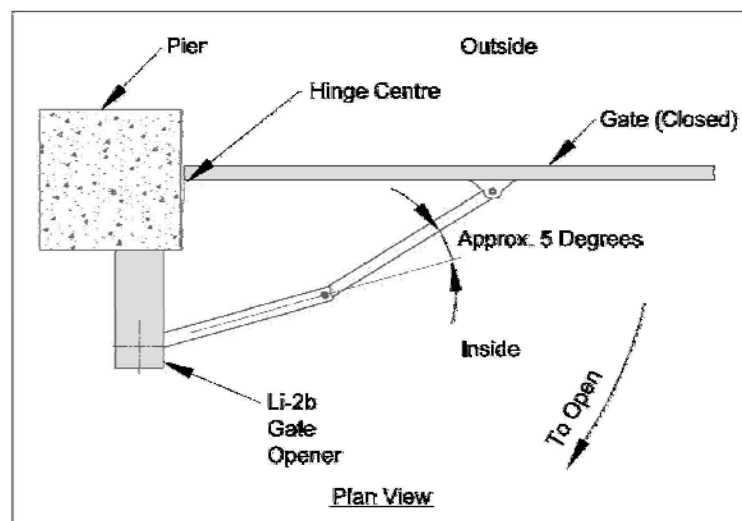

Figure 4: Standard installation.

LI-2B Installation Manual

6. Connect Power (12 volt or 24 volt or solar) to the Primary operator and connect the battery
7. The Limit Switches may now be adjusted (See figure 5). Each of the Master and Slave operators has its own pair of cams, one to set the open position and one to set the closed position. Firstly mark the position of each cam as a reference. Loosen the screw holding the cams. Operate the LI-2B operator with the transmitter and note which cam controls opening and which cam operates the closing motion. (The cam lobe activates a Limit Switch to turn off the motor). Reposition each cam and operate the LI-2B again. Repeat until the gates open and close to the required positions.
- 8.

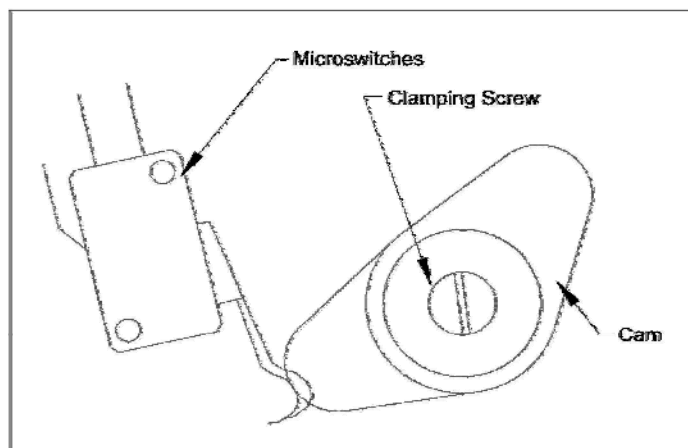

Figure 5: Limit switches

LI-2B Installation Manual

Side Mount Installation

The LI-2B operator may be mounted sideways with the long side against the pier/post for extra flexibility.

This feature is very useful for situations where (Refer to figure 6)

- The gate must swing further than 90 degrees
- The gate swings outwards
- The gate swings outward and it is positioned at least 400mm forward of the back of the pier/post

Note: See section on out swing installation.

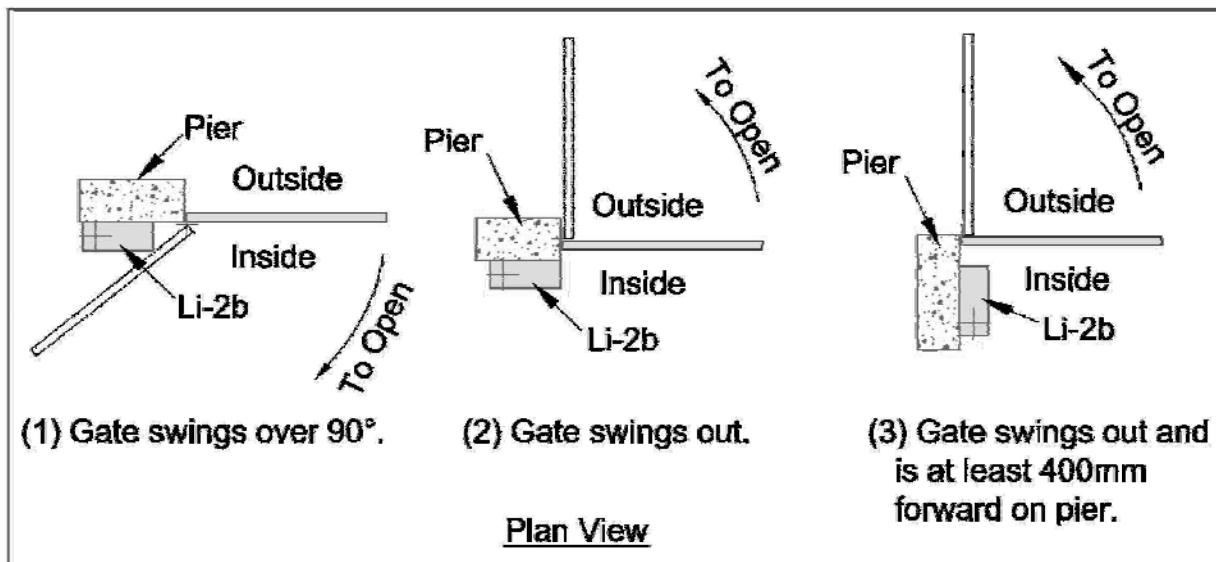

Figure 6: Side mount installations.

Each LI-2B operator should be fitted to the pier/post with its output shaft close to the gate hinge. With this in mind the “Standard Installation” instructions may now be followed. Special covers are supplied to suit this type of installation.

LI-2B Installation Manual

Restricted Side Room Installation

This term is applied to the situation where the movement of the standard arms cannot be accommodated within the side room available. In most situations this problem can be overcome by cutting down the secondary arm. (The link joining the gate to the primary arm).

This new length can be approximated by the following procedure.

1. Move the primary arm to a position suitable for the closed gate. Remembering that in the closed position the primary and secondary arms must stop short of a straight-line alignment (See Figure 7).

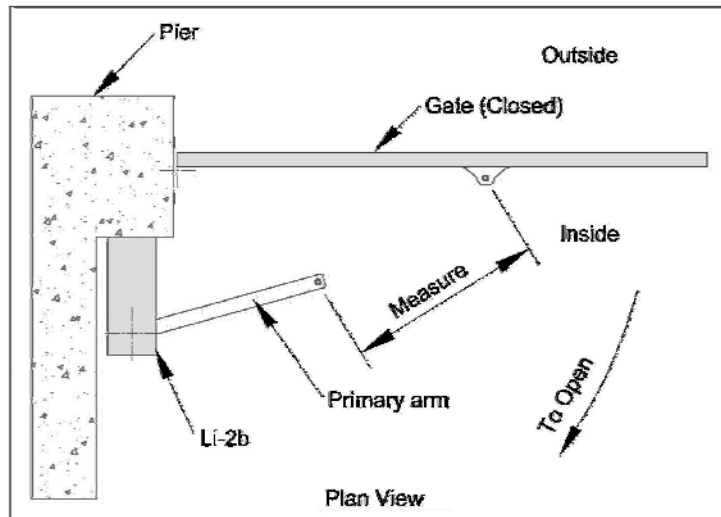

Figure 7: Measure length of secondary arm.

2. Mark a point on the gate suitable for the gate bracket. Holding the gate bracket in position, measure the distance between the hole centres on the gate bracket and primary arm. Move the primary arm to its maximum open position. Open the gate and measure the distance again. (See figure 8). If the length has changed then the gate bracket must be repositioned and the same process repeated until the dimensions remain the same for both positions. **Be careful that the secondary arm does not conflict with the drive shaft of the primary arm.**
3. Once the dimensions are consistent a new hole can be drilled in the secondary arm and the arm trimmed to suit. The gate bracket and secondary arm should now be fitted.

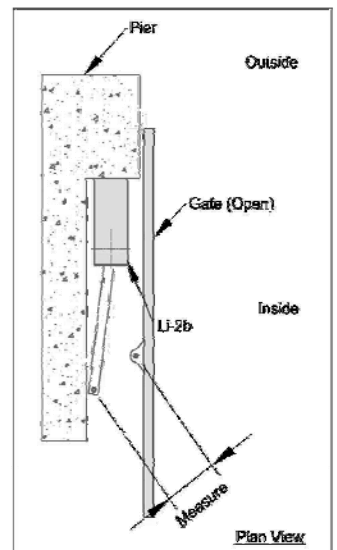

Figure 8: Re-measure length of secondary arm.

LI-2B Installation Manual

Out-Swing Installation

In this type of installation the gate swings outward away from the LI-2B operator to the open position.

Several factors must be considered to determine the most suitable arm length. These include

- The drive through width required
- The placement of the gate operator
- The location of the gate on the pier/post

For assistance (if required) please provide a drawing (mud map) of your situation showing all possible measurements.

Possible measurements include width between piers/posts, size of piers/posts, single or double gates, position of hinges on piers/posts etc.

Note: The polarity of the motor connections may need to be reversed for out-swing operation. See overload section.

LI-2B Installation Manual

Settings

Auto Close

The operator control board is supplied with a “JUMPER” installed on a three-pin block. This allows the gate to automatically close after a specific period. This period is adjustable. (Refer to figure 9).

- Turn ‘Auto Close delay’ dial (Trimpot) Anti-clockwise to increase the hold open time delay before gate closes automatically.
- Turn/dial trimpot clockwise to shorten the hold open time delay before gate closes automatically.

Travel Time

There is a “Travel Timer” and a yellow LED and trimpot dial located to the left of the Auto close Jumper. This should be set to approximately 5 to 10 seconds after full operation after gate(s) reach full travel on limit switches in OPEN and CLOSED position (See figure 10).

Travel time can be adjusted by turning dial/trimpot Anti-clockwise to extend travel time and vice-versa.

Green LED – Open Position (Located above relay 4)

Red LED – Close Position

This “JUMPER” fits onto any two of three pins

- If fitted on pins 1 and two the gate is set to close automatically.
- If fitted on pins two and three the gate will require a signal to close
- If there is no “JUMPER” or it is lost the gate will close automatically.

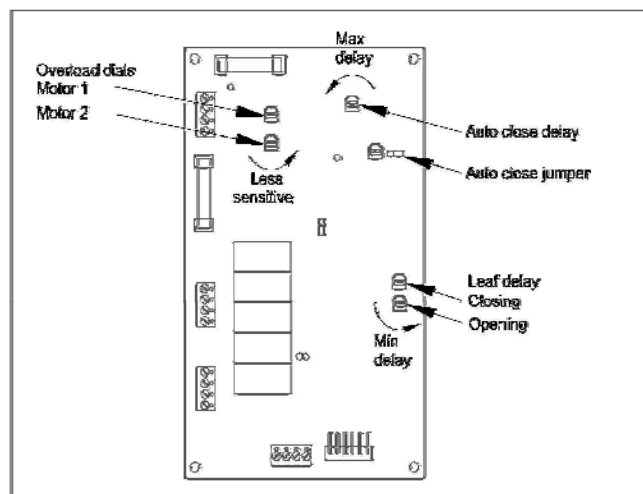

Figure 9: Settings.

LI-2B Installation Manual

Multi-User Function

This function is for when the LI-2B gate operator is installed for multi-users (e.g. flats, Apartments etc.) There is a Jumper installed on a three-pin block approximately in the middle of the main control board. If the Jumper is on pins one and two the operator WILL NOT allow the gate to close on a signal, it will continue to open position, time out then auto close. If the Jumper is on pins two and three (Normal) a signal e.g. from the remote control will reverse the direction of the operator.

Overloads

The overloads (See figure 9) are preset to maximum sensitivity, i.e. slight pressure will cause the operator to STOP if it is opening or STOP & OPEN if it is closing.

Note: If these functions are reversed i.e. the gate STOPS when closing and STOPS and REVERSES when opening then the polarity of the motor connections MUST be reversed and the limit switch cams adjusted.

There is ONE overload for each gate as indicated on the main circuit board. To reduce the sensitivity on the main circuit board turn the overload dials in the Anti-Clockwise direction.

BE CAREFUL large reductions in sensitivity may allow the gate(s) to exert excessive pressure on people or vehicles trapped in the path of the gate(s).

Anti-Clash Leaf Delay for Pairs of Gates

To avoid jamming there is a time delay between the movements of each gate. This delay may be independently adjusted for the Opening sequence and the Closing sequence.

Dial "R24" changes the closing delay and "R27" changed the opening delay.

In situations where the master operator is on the right hand side looking out, the "R24" sets the Opening delay and "R27" sets the Closing delay.

Turning the dials/trimpots Anti-Clockwise gives the minimum delay.

LI-2B Installation Manual

Push-Button, Key -Pad etc.

A variety of hard-wired input devices can be used to operate the LI-2B operator. Input should be in the form of a **MOMENTARY CLOSED CIRCUIT**.

WARNING! Voltage must not be applied to these terminals. **DAMAGE** to the circuitry will result if voltage is applied. Devices that send a Voltage Pulse (As some intercoms do) must be connected to the circuit board through a relay.

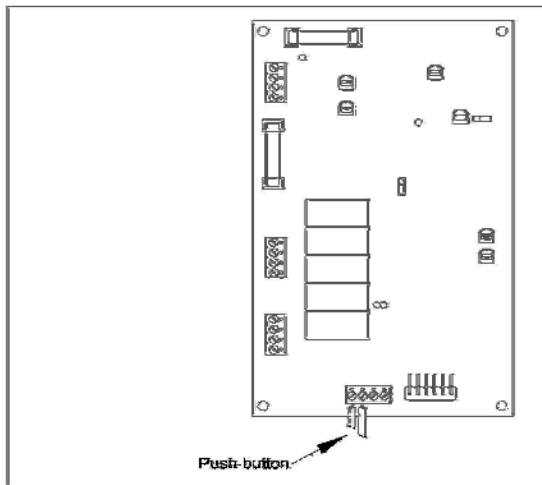

Figure 10: Push-button connection.

Electric Lock

Connections for an electric lock/latch (EL) are provided on the circuit board. (See Figure 9) This connection block will supply 12 Volts to energise the lock at the beginning of the Opening and Closing cycles.

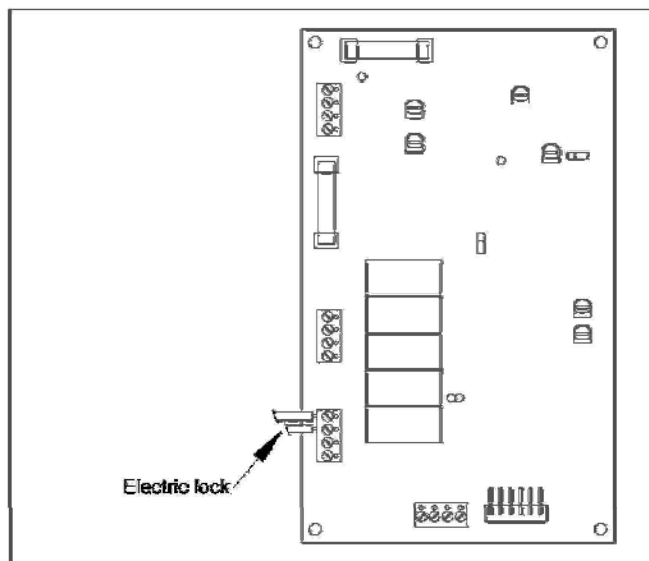

Figure 11: Electric lock connection.

LI-2B Installation Manual

Photoelectric Safety Cell (240 volt & 12 volt operators only)

A photoelectric safety cell (PE) may be fitted to detect obstructions in the path of the gate(s). The PE will check for obstructions during the closing cycle only. If an obstruction is encountered the gate(s) will reverse to the open position.

If the gate is set in the automatic close mode the gate(s) will remain open until the obstruction is cleared.

Wires from the PE should be attached to the appropriate connection block. (See figure 9)

Note: Extra power consumption will occur when using Photoelectric Cells so extra panel(s) and battery(s) will be required when gate(s) are operating on solar power only.

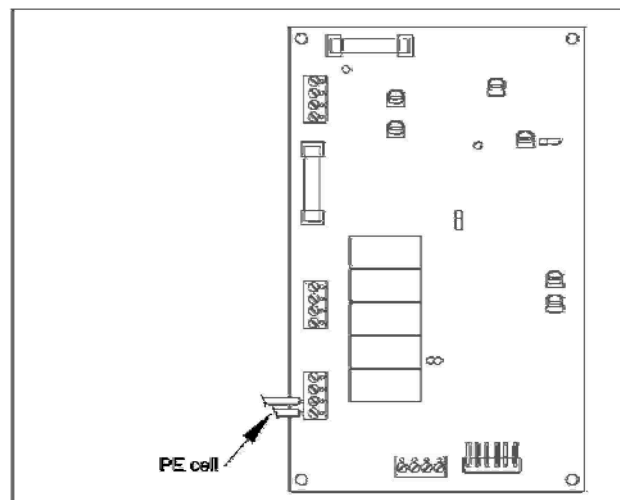
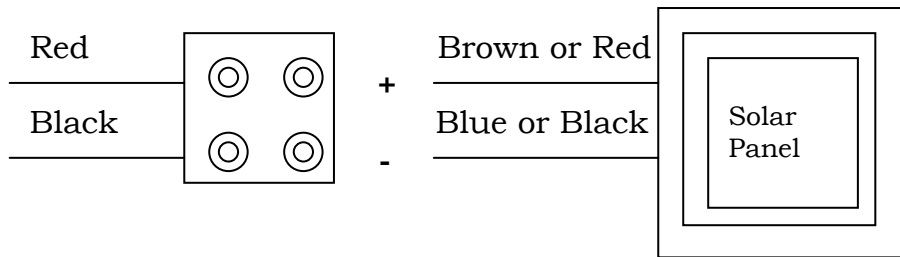

Figure 12: Photoelectric cell connection.

LI-2B Installation Manual

Solar Wiring Detail Step 1

Locate two way terminal connection block on top plate near motor. This will have Red (Positive) and black (Negative) wires. Connect solar panel direct to it.



IMPORTANT

As a connected solar panel delivers a charge, the solar panel must be covered or disconnected when any work or wiring is being done on the control board (other than when adjusting trimpots or limit switches)

Step 2

Locate RED wire with spade terminal (Which will be disabled from Positive on Battery). Connect this wire and you are ready to set your limits.

Negative Wire is already connected

Locate Positive Wire (RED)
Connect RED wire to + on battery

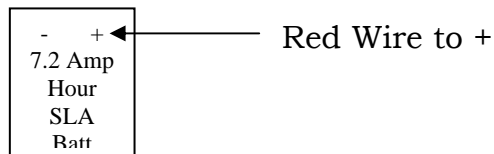

Note: All LI-2B gate operator kits (Solar, 240 volt and 12 volt) are supplied complete with a 7.2 Amp hour battery. This battery should be checked regularly.

LI-2B Installation Manual

Trouble Shooting

Poor range with the radio transmitter (Tx). Our standard transmitters are factory tested to 200 metres. 433Mhz Antenna is generally included to maximize signal to the radio receiver (Rx). Poor range may occur for several reasons. The first two things to check are:

- A. The Battery in the Tx
- B. Antenna installation and wiring

Other causes is interference from other radio sources such as

- Electric fences
- Baby Monitors
- Other local transmitters

Here the best solution is to remove the external source. If this is not possible the problem may sometimes be solved by using special frequency transmitters and a matching radio receiver (Rx). These are options that must be specifically ordered.

Other faults may be due to incorrect settings. Refer to “Settings” section of this manual to ensure the settings are correct.

LI-2B Installation Manual

Specifications

Dimensions

Case: 245mm (H) x 140mm (W) x 335mm (D)

Primary Arm: Pivot Centres 550mm

Secondary Arm: Pivot Centres 570mm

Weight

Master Unit including battery	21kg
-------------------------------	------

Slave	17kg
-------	------

Remote Control Systems

Arco can supply hand held transmitters and receiver boards. There are three models of hand transmitters available – single, two and four button. The multi-button units allow individual operation of several devices (gates, doors etc.) from one hand transmitter.

Where a system is already installed, on say the garage door, conversion kits can be fitted to allow operation of the door and gates from one multi-button transmitter.

Power Requirements

Standard240 Volts 50Hz AC

LI-2B Installation Manual

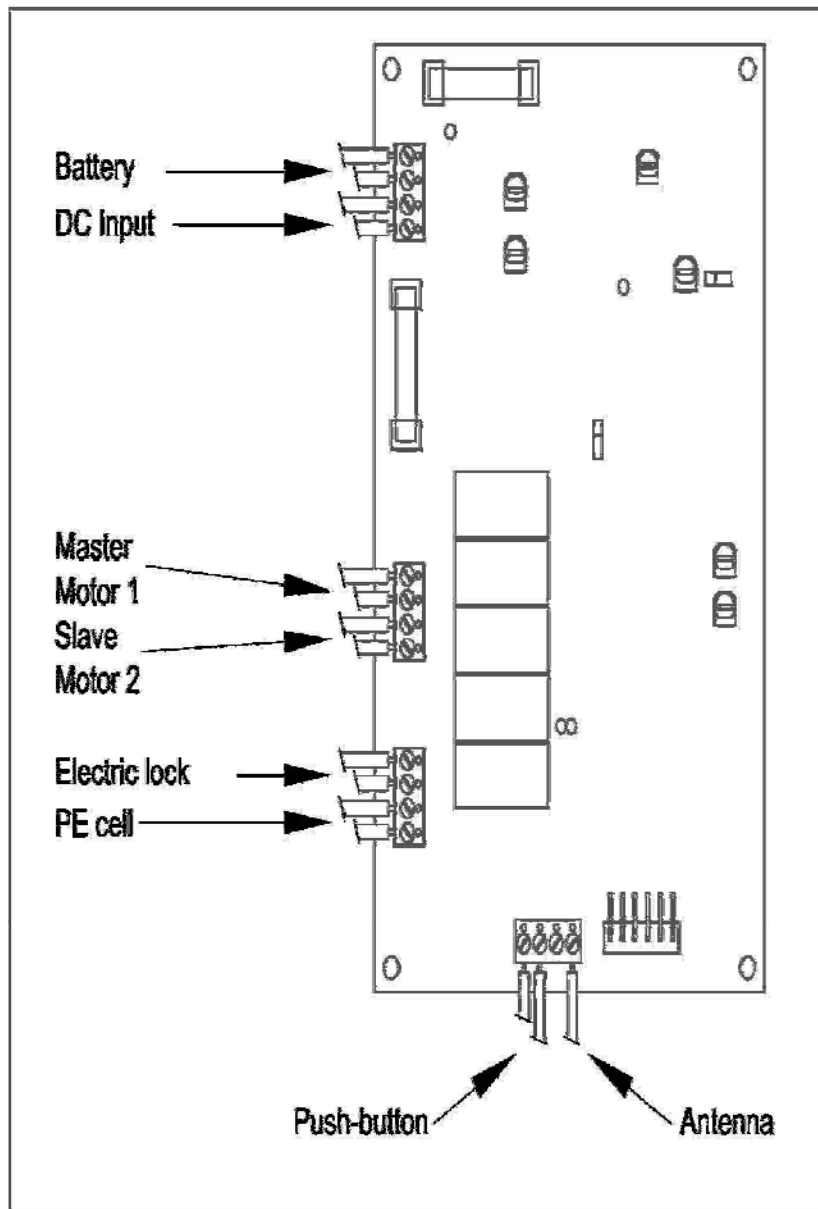

Figure 13: Control circuit connections.

LI-2B Installation Manual

