















ID200 Control board for 2 motors 12-24V

Important: Read this manual carefully before the installation. This manual is an integral part of your product, keep it for reference.

Warnings:

-  First of all verify that this product is suitable for the installation.
-  Read carefully technical characteristics before the installation.
-  Installation of this control unit must be by qualified installers, following regulations of the installation country.
-  It is mandatory to do periodic maintenance.
-  Maintenance or repairs must be performed by qualified technicians.
-  Turn the power off before maintenance or repairs.
-  This device is intended for gate automation, any other applications is not advised.
-  Manufacturer discharges all responsibility for missed respect of rules.
-  Don't leave this control unit unattended or where children can reach

Preliminary checking:

-  Verify that all the connected devices meet the technical characteristics listed in the table which follows.
-  Verify that a working and suitable RCD is installed up line of the installation.
-  Verify that cables composing the installation are suitable for it.

Conformity declaration:

The manufacturer:

Declares:

The control unit ID-200 is compliant to following directives:
 - 2006/95/CE Low voltage directive.
 - 2004/108/CE Electromagnetic compatibility.

Castiglione 30/07/2015

Technical characteristics	
Power Supply	12-20Vac/100-200VA
Max current out (14-15)	250mA
Embedded battery charger	12-24V, 100mA
Max. motor current	8A (200VA transformer)
Max. flashing light current	1A
Electric-Lock current	2A
Operating temperature range	-5 +60°C
Backup battery	(2x) 12V 4,5Ah

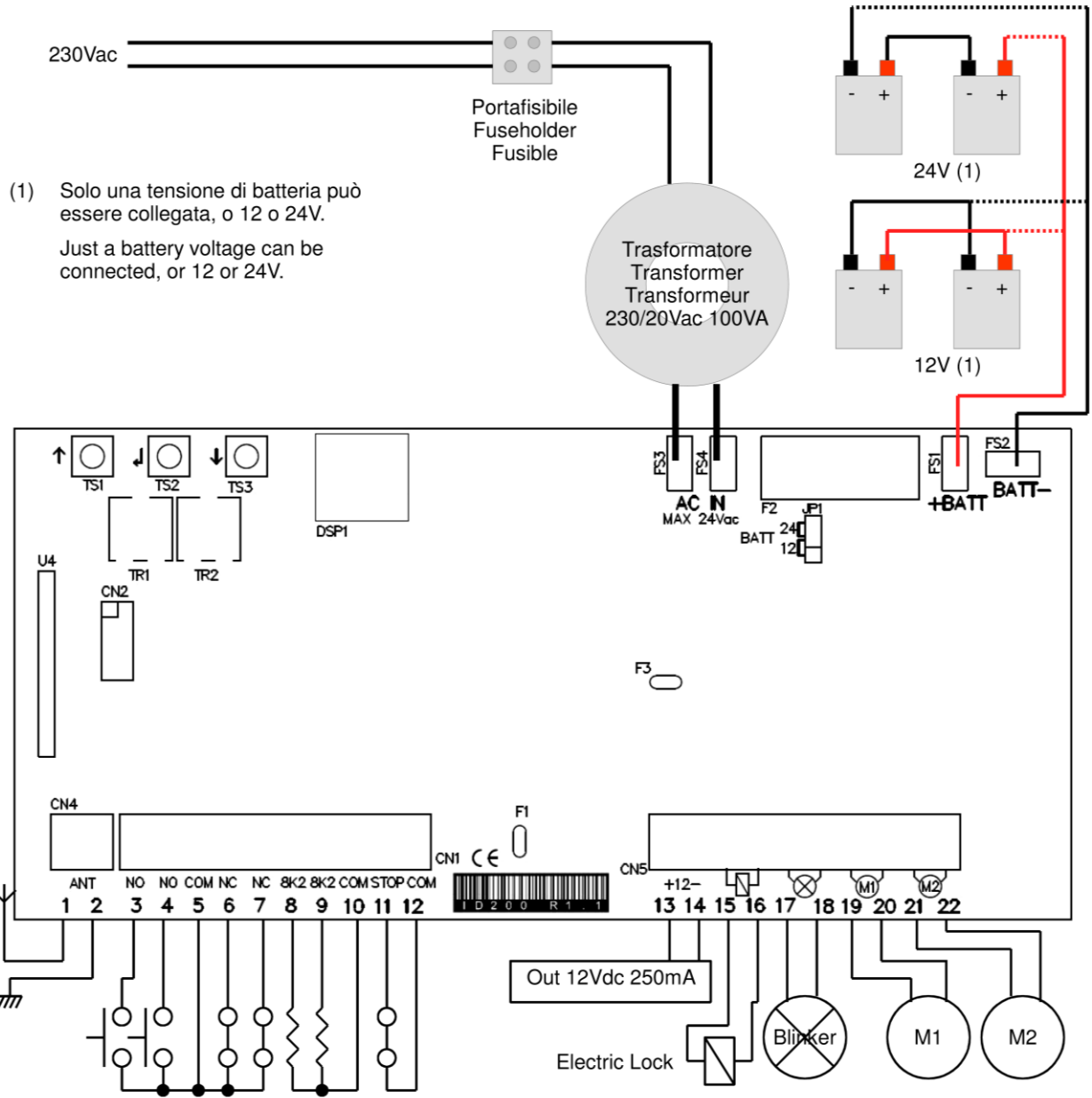

1	Antenna
2	Antenna's shield
3	Start input (NO) It completely opens the gate
4	Pedestrian start in. (NO) It opens just motor 2
5	Common
6	Photocell input (NC) During pause: Reloads pause During closing: Reverses motors direction
7	Photostop input (NC) During pause: Reloads pause During closing: Reverses motors direction During opening: stops the motors and waits till contact returns close.
8	Analog opening edge input (8K2 ohm) Waiting an opening command: inhibits opening During opening: reverses motor direction for 1 second. If not used leave unconnected.
9	Analog closing edge input (8K2 ohm) Waiting a closing command: inhibits closing During closing: reverses motor direction for 1 second If not used leave unconnected.
10	Common
11	Stop input (NC) It always stops motors and blocks control unit activity.
12	Common
13-14	Power supply output 12Vdc 250mA
15-16	Electric lock output
17-18	Flashing light output 12/24V 1A
19-20	Output motor 1 - 8A
21-22	Output motor 2 - 8A
TR1	Slowing down speed trimmer
TR2	Obstacle detection sensibility trimmer
TS1-TS3	Buttons up/down
TS2	Enter button
DSP	Display
FS3 - FS4	Transformer input 12-20Vac / 100-200VA
F2	Battery fuse 10A Fast
FS1 - FS2	Backup battery input 12/24Vdc
JP1	Backup battery voltage selector 12/24V

INPUT STATUS

When the control unit is waiting for an opening or closing cycle, or when it's in pause, status of inputs is displayed as following diagram.

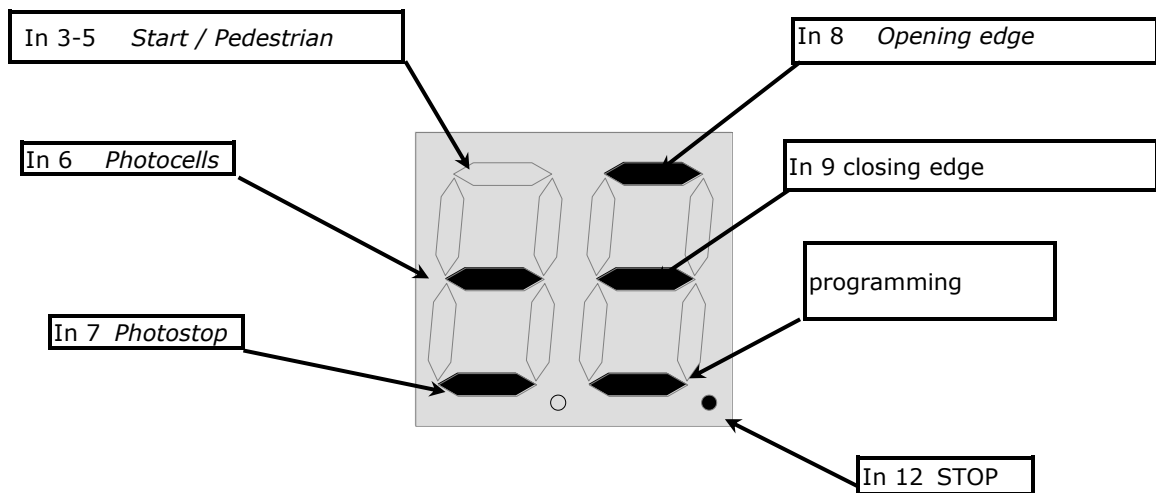

TRIMMER REGULATIONS

TR1 The slow down speed trimmer regulates the slow down speed. Do not set speed to low (less than 10cm/sec on the wing edge) to avoid that gate stops in too cold conditions.

TR2 The obstacle sensibility trimmer fine tunes the obstacle detection level learned by the control unit during working times programming. This fine regulation must be done after working times learning. Normally the trimmer goes in the center, in this position it should be possible to respect the rules of most installations. If it is need to resolve problems related to norms or to environmental situations (ex. strong wind) is it possible to regulate this trimmer increasing or decreasing sensibility.

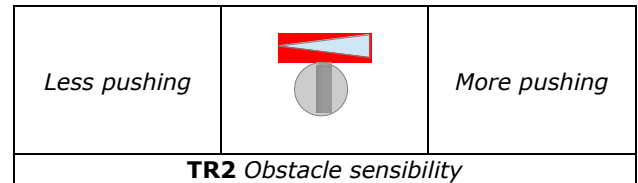
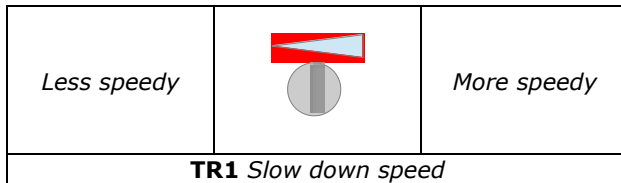

QUICK INSTALLATION - To program quickly the working times, open both wings, then keep pushed up (TS1) until you read **AU** on the display. The control unit will perform several tests and then it will learn working times. When the procedure is finished the blinker goes off.

USE OF DOWN MENU AND UP BUTTONS FOR PROGRAMMING

Control unit function programming is made within a special configuration menu which you can access and program using the UP (TS1), ENTER (TS2) and DOWN (TS3) keys.

The configuration menu consists in a list of configurable items; the display shows the selected item.

- By pressing DOWN, you will pass to the next item
- By pressing UP, you will return to the previous item
- By pressing together UP and DOWN buttons you exit from the item
- By pressing ENTER, you can view the current value of selected item and possibly change it.

There are 2 main menus:

- **BASE PROGRAMMING** (BASE MENU): only the useful parameters for a base programming are displayed.
- **ADVANCED PROGRAMMING** (ADVANCED MENU): parameters of the advanced menu are displayed.

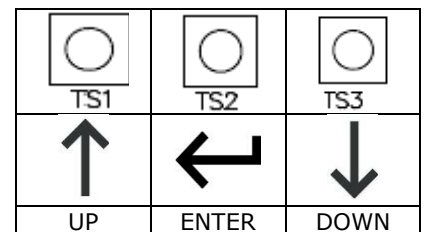

BASE MENU MAP

Press the ENTER key for 1 second for base menu.

 ← 1 SEC.	OL	<i>Operating logic</i>	← ↓↑	5T	Step by step logic.
				At	Automatic closing with stop function.
				CD	Automatic closing for condominium function.
				EX	EXIT or push ↓↑ together
		↓↑			
	LC	<i>Learns radio codes</i>	← ↓↑	C1	Learn a transmitter on channel 1
				C2	Learn a transmitter on channel 2
				rt	Delete a code with transmitter*
				EX	EXIT or push ↓↑ together

LC Learning / removing transmitters code:

Select learning code function LC and push enter, than select one of following functions with up/down.

C1: learn a transmitter on channel 1

C2: learn a transmitter on channel 2

RT: Delete all transmitters in memory.

Once the channel is selected press the desired button on the transmitter, on the display it will display "**OK**" if the operation was successful.

- To delete just one code, select **RT** and transmit the code to be removed, on the display it will display "**OK**" for a successful transmission.

- To delete all codes, select **RT** and push enter, then confirm with **YS**.

To exit this menu select **EX** or push up/down together.

↓↑

LT	<i>Learn working times</i>	← ↓↑	AU	Automatic learning procedure.
			MN	Manual learning procedure.
			EX	EXIT or push ↓↑ together

LT learn working time:



Attention: before starting the learning procedure, the gate must be open to do an automatic procedure; otherwise it must be closed to do the manual procedure. Use manual override to put the gate in the correct position.

Select **LT** in the base menu and push enter, next select the learning mode with up/down.

AU: Automatic learning procedure.

MN: Manual learning procedure.

To exit this menu select **EX** or push up/down together.

AU Automatic procedure for working time learning:



Attention: in this procedure all safety inputs are disabled.

The wings close themselves, during this process all of the working times and values for obstacle detection sensors are learnt. If only motor 2 is connected, the control unit sets itself for "single wing working. If analogue edges are connected, they are automatically enabled.

MN Manual procedure for working time learning:



Attention: Before this procedure program at least one transmitter into memory. In this procedure all safety inputs are disabled.

Both wings start opening, during this phase you can adjust the slow down speed with the trimmer (TR1). Once both wings are open, press and release your programmed remote control. The control unit makes some tests of motor consumption to set the threshold for the obstacle detection sensor.

Once the test is finished, you will see **M1** on the display.

In the phase which follows, enter button or a memorized code control following sequence: start motor 1, start motor 2, slow down motor 1, slow down motor 2, stop motor 1, stop motor 2.

If just motor 2 is connected (single wing mode), program times just for this motor.

↓↑

5P	<i>Set pause time</i>	←	↓↑	0 - 99
-----------	-----------------------	---	----	---------------

5P Set pause time: - Use up/down to set the pause time between **0** and **99** seconds. Pushes enter to confirm. To exit without modifications push together up and down.

Attention, setting a pause time doesn't enables automatic closing; please refer to chapter "**0L** operating logic" to enable this function.

↓↑

DM	<i>Dead man mode</i>	← ↓↑	01	Open motor 1
			C1	Close motor 1
			02	Open motor 2
			C2	Close motor 2
			EX	EXIT or push ↓↑ together

DM Dead man mode:

Selecting this menu it is possible to control each motor in dead man mode. Push up and down to select one of following item:

01 Open motor 1

C1 Close motor 1

02 Open motor 2

C2 Close motor 2

EX Exit -

Press and hold the enter button to start the selected motor in dead man mode.

↓↑







EX	<i>Exit</i>	←
-----------	-------------	---

BOARD PROGRAMMING ADVANCED MENU





Push enter button till on the display is shown **TM**. With up/down it's possible to select all items in this menu. To exit this menu select **EX** or push up/down together. After 2 minutes without actions, control unit exits itself from this menu.

ADVANCED MENU MAP

Press the ENTER key for 4 seconds for advanced menu.





	TM	<i>Working times menu</i>	  	T1	Working time motor 1	  0 - 99
				51	Start time slowdown motor 1	
				T2	Working time motor 2	
				52	Start time slowdown motor 2	
				DO	Motors delay opening	
				DC	Motors delay closing	
				TC	Courtesy light time x10sec.	
				TL	Electric lock activation time	
ex	EXIT or push  together					







5G	<i>Single gate mode</i>	  	YS	Single wing YES
			NT	Single wing NOT
			ex	EXIT or push  together

5G Single wing mode: In this menu it's possible to verify or set if gate works in single wing mode (motor2)



D2	<i>Loads factory defaults</i>	  	YS	sets the control unit at factory defaults.
			NT	Maintain settled parameters
			ex	EXIT or push  together







RC	<i>Release end travel torque</i>	  	YS	Enable release end travel torque
			NT	Disable release end travel torque
			ex	EXIT or push  together

RC Release torque at work end:





Enabling this function, the motors reverse direction for a while to release the torque at end of work.



Eo	<i>Analogue edge in opening</i>	  	YS	Enable
			NT	Disable
			ex	EXIT or push  together





Eo Enabling this function it's enabled the edge active in opening period



Ec	<i>Analogue edge in closing</i>	  	YS	Enable
			NT	Disable
			EX	EXIT or push  together

Ec Enabling this function it's enabled the edge active in opening period



Ar	<i>Transmitters auto learning</i>	  	YS	Enable
			NT	Disable
			EX	EXIT or push  together

Ar Enable automatic transmitters leaning:

Enabling this function it's possible to insert new transmitters without accessing base menu. Refer to "Automatic transmitters learning".



LP	<i>Low power mode</i>	 	YS	Enable
			NT	Disable
			EX	EXIT or push together

LP Enable low power mode:

In this menu you can enable the low power mode.



Attention: If enabled, the display is no longer showing input status (Display off in stand-by).



C5	<i>Kickback stroke</i>	 	YS	Enable
			NT	Disable
			EX	EXIT or push together

C5 Enable kickback stroke:

In this menu you can enable the stroke at start to unlock electric lock and the final stroke to lock it.



EX	Exit		
-----------	------	--	--

QUICK TABLE BASE MENU

Default settings

Here it follows list of default settings, the same set after a **D2** command of advanced menu

DISPLAY	DESCRIPTION	DATA	DESCRIPTION	DEFAULT	DATA
oL	<i>Operating logic</i>	St	<i>Step by step</i>	St	
		At	<i>Automatic closing with stop funcion.</i>		
		cd	<i>Automatic closing uninterruptible CONDOMINIUM</i>		
		EH	<i>EXIT</i>		
Lc	<i>Learning / removing transmitters code</i>	c1	<i>Learn a transmitter on channel 1</i>		
		c2	<i>Learn a transmitter on channel 2</i>		
		rt	<i>Erase codes</i>		
		EH	<i>Uscita</i>		
Lt	<i>Learn working time</i>	Au	<i>Automatic learning procedure</i>		
		Mn	<i>Manual learning procedure</i>		
		EH	<i>EXIT</i>		
SP	<i>Set pause time</i>	0"-99		10 sec	
dM	<i>Dead man mode</i>	o1	<i>Open motor 1</i>		
		c1	<i>Close motor 1</i>		
		o2	<i>Open motor 2</i>		
		c2	<i>Close motor 2</i>		
		EH	<i>EXIT</i>		
EH	<i>EXIT</i>				

QUICK TABLE ADVANCED MENU

DISPLAY	DESCRIPTION	DATA	DESCRIPTION	DEFAULT	DATA
tM	<i>Working times menu</i>	t1	<i>Working time motor1</i>	30 sec	
		S1	<i>Start time slowdown motor1</i>	20 sec	
		t2	<i>Working time motor2</i>	30 sec	
		S2	<i>Start time slowdown motor2</i>	20 sec	
		do	<i>Motors delay opening</i>	02 sec	
		dc	<i>Motors delay closing</i>	05 sec	
		tL	<i>Electric lock activation time</i>	02 sec	
		EH	<i>EXIT</i>		
SG	<i>Single wing mode</i>	yS	<i>Yes</i>	nt	
		nt	<i>No</i>		
		EH	<i>Exit</i>		
d2	<i>Default settings</i>	yS	<i>Yes</i>		
		nt	<i>No</i>		
		EH	<i>EXIT</i>		
rc	<i>Release torque at work end</i>	yS	<i>Yes</i>	nt	
		nt	<i>No</i>		
		EH	<i>EXIT</i>		
Eo	<i>Analogue edge in opening</i>	yS	<i>Yes</i>	nt	
		nt	<i>No</i>		
		EH	<i>EXIT</i>		
Ec	<i>Analogue edge in closing</i>	yS	<i>Yes</i>	nt	
		nt	<i>No</i>		
		EH	<i>EXIT</i>		
Ar	<i>Transmitters auto learning</i>	yS	<i>Yes</i>	ys	
		nt	<i>No</i>		
		EH	<i>EXIT</i>		
LP	<i>Low power mode</i>	yS	<i>Yes</i>	nt	
		nt	<i>No</i>		
		EH	<i>EXIT</i>		
C5	<i>Kickback stroke</i>	yS	<i>Yes</i>	nt	
		nt	<i>No</i>		
		EH	<i>EXIT</i>		
EH	<i>EXIT</i>				

Diagnostic and troubleshooting

The control unit has self-diagnostic software able to find problems. Once a problem occurs, a code is shown on the display in alternate with command status.

Here it follows a troubleshooting table.

Error code	<i>Problem and eventual solution</i>
E1	Mains power fail, system is running with backup battery. <i>Verify mains switch and RCD switch. Verify fuse on transformer (fuse holder)</i>
E2	Obstacle detected in the previous cycle. <i>Verify that gate is free and there are no obstacles in the range. Verify gate wings are not blocked.</i>
E3	Photocells or photostop obstructed for longer than 2 minutes. The gate can't start moving and the blinker could be fixed on. <i>Verify that photocells and photostop are not obstructed.</i>
E4	One of the analog edges is engaged for longer than 2 minutes. <i>Verify edges aren't engaged. If no edge installed, disable them in the advanced menu</i>
E5	Stop is engaged for longer than 2 minutes. <i>Verify wiring to emergency device. If there isn't an emergency device installed, shunt this input with the common.</i>
E6	Problem on motor 1. <i>Verify connections to the motor, verify motor can work in manual mode</i>
E7	Problem on motor 2. <i>Verify connections to the motor; verify motor can work in manual mode.</i>

