

AUTOMATIC SOLUTIONS

Australia Pty Ltd

ASA300 - K50

**IMPORTANT – MANUAL
OVERRIDE CAP MUST BE
ON AT ALL TIMES**



GENERAL

ASA300

Motor Voltage – 12 volt
Power Absorbed – 70 watts
Speed – 0,019 metres per second
Maximum Thrust – 1500 N
Protection Level – IP43
Duty Cycle – 90%
Dimensions – 670L x 90W x 185H
Stroke – 30 CM
Maximum Leaf – 3.0 metres
Maximum Leaf Weight – 250 Kg
Opening Time – 16 Seconds

K50

Motor Voltage - 12 / 24 DC
Motor Inputs - Two
Battery Charger – Inbuilt 12/24V
Receiver – Inbuilt or External
Limit Switches – Yes / No
Pedestrian Input – Yes (NO)
Start Input - Yes (NO)
Stop Input – Yes (NC)
Photocell Input – Two (NC)
Electric Lock – Yes 12Vdc 1A
Slow Speed Regulator – Yes

IMPORTANT— READ THIS FIRST

Parts of these instructions are intended as a quick start guide and should be used in conjunction with the full instructions. The quick start instructions provide the basics to get you up and running and are based on the most commonly used installations in Australia. All electrical work in this country is to be performed by licensed electrical contractors. Electricity can kill!

SAFETY

This booklet will offer you information you may need to install your gear motor and to safeguard your safety.

However, caution is unquestionably indispensable and nothing is better than preventing accidents.

WARNING: any repair or adjustment of working machinery is strictly prohibited unless all the necessary precautions (electrical supply disconnected and motor off) have been taken in order to avoid possible accidents.

WARNING: any repair must be carried out by qualified people.

WARNING: All moving mechanisms must be provided with suitable protections.

WARNING: Keep the automatic controls out of the reach of children.

WARNING: Command pulses must be given from positions where the gate is visible.

WARNING: Use transmitters only if you can see the gate.

Read carefully the instructions enclosed in this manual.

Keep this booklet in a suitable place well known to all interested people.

PRELIMINARY CHECKS

In order to make the automation work efficiently; the gate to automate must have the following characteristics:

- It must be balanced.
- It must oscillate fluently.
- You must be able to carry out manual closing and opening of the gate without any effort.
- Make sure that the gate has a solid structure and that there is no friction points in its movement.
- Make sure that the gate/s have both solid opening stops and solid closing stops.

GENERAL ORDER OF INSTALLATION

To ensure a good installation of the gear motors ASA300, we suggest the following order of installation:

- 1 - Open the box and take out gear motor. Inspect the contents and ensure all components are present.
- 2 - Make sure that the leaf of the gate is perfectly horizontal.
- 3 - Determine the height position of your motor and mark post bracket position.
- 4 - Spend some time here considering the correct height and geometry of your post bracket.
- 5 - Attach the gear motor on to the support post.
- 6 - With gate/s leaf closed, turn and slide the screw of gear motor's shaft, until it comes to the end of the screw.
- 7 - Screw shaft back 1 complete turn of 360°.
- 8 - Place the gate support plate in the hole of the shaft end and position it against the gate leaf.
- 9 - Fix it to the gate leaf taking in account the inclination.
- 10 - Put the gear motor into manual operation mode with your override key and test your install for smoothness.
- 11 - If correct proceed in the same way with the other gate leaf.
- 12 - Place the mechanical limit stops
- 13 - Connect the gear motors to the logic controller.
- 14 - Program and test your installation
- 15 - Attach your safety devices and access devices one by one testing for correct operation at each point.

MAINTENANCE

Periodically check your installation for loose or worn fastenings, correct alignment and operation of your gate/s and correct operation of your manual override operation. Clean and keep clean all areas of the installation. Remember that the motorisation has been planned in order to help you use the gate. This means that it does not resolve the problems caused by an inadequate installation or by a poor upkeep of the gate.

ASA300 GEAR MOTOR INSTALLATION

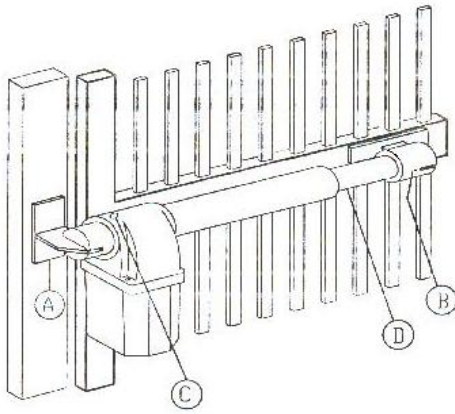

INSTALL POST BRACKET

The position of the post bracket "A" is critical to the success of your installation and attention needs to be paid to both its correct height and also its position on the post in respect to the relationship between your gate hinge pivot point and the motor pivot point on the bracket.

Once you have determined the general desired height of your motor, position the bracket and take note of dimensions "J" and "K". In a standard installation the basic aim is to get dimensions "J" and "K" to be as close as possible to equal.

The other consideration before fixing the post bracket is that the pivot point of the post bracket "A" should be 12mm higher than the pivot point of the gate bracket "H" giving the gear motor an incline of approximately one degree.

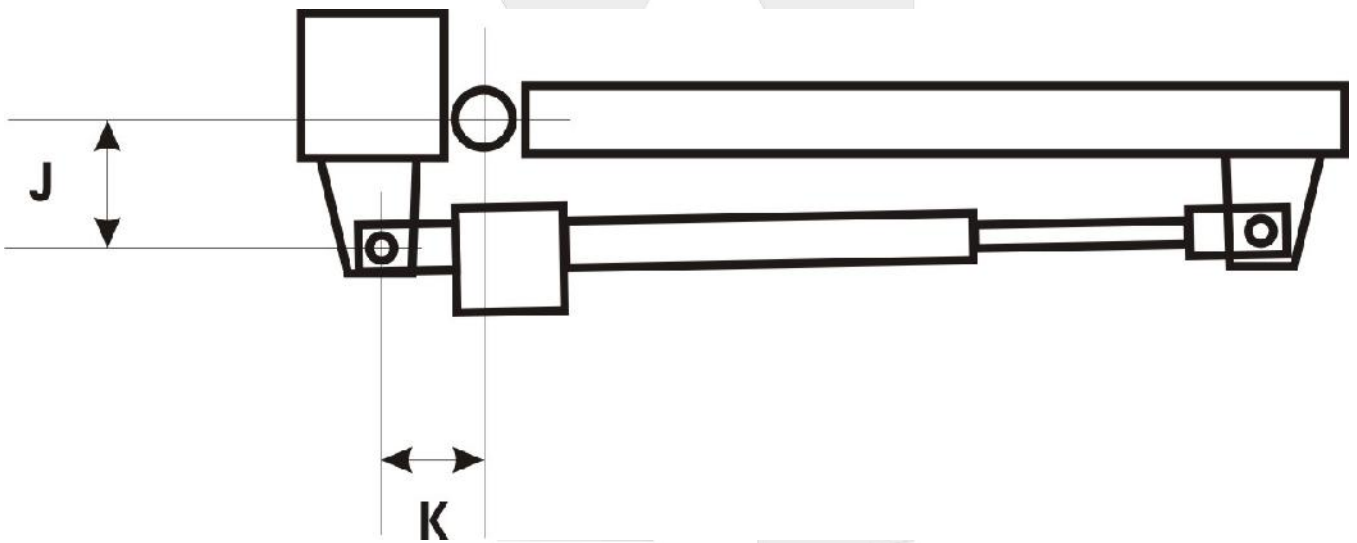

INSTALL GATE BRACKET

With your post bracket securely fastened, attach your gear motor to the post bracket with the bolts provided. Take care to support the weight of the gear motor at this point and throughout this stage. Wind out shaft "D" all the way till the end. Now turn shaft "D" back one complete turn of 360 degrees. Attach your gate bracket to the shaft end "H" and position on the gate taking careful note of your 12mm fall from the post bracket. Fix your gate bracket at this position. Using your manual override key put the gear motor into manual mode and gently move your gate and gear motor through the entire 90 degree arc to test the smoothness of your installation. If your gate and gear motor moves smoothly through the entire travel range then you are ready to proceed to the next point. If you are having difficulty or hitting sticking points at any point in the travel you may need to adjust your post bracket pivot point to facilitate a smoother run.

INSTALL GATE STOPS

This is a critical point in ensuring long trouble free operation of your automation system, yet it is relatively simple. Each gate must have a positive and well secured opening stop and closing stop. There are a range of stops available over the counter or you can make them yourself but the critical point is that the stops must be well secured as the gear motors will exert quite a deal of force on them during programming. In summary when your gate/s open they must hit a positive stop point that stop the gate/s from opening any further and the same at the closed point.

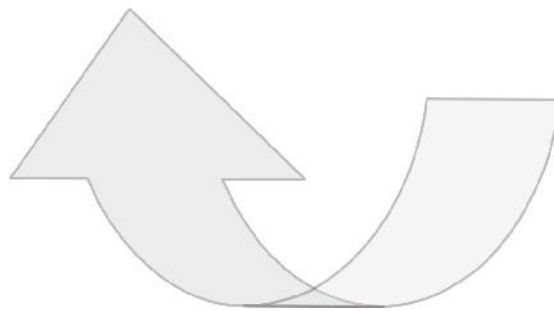

K50 LOGIC CONTROL BOARD INSTALLATION

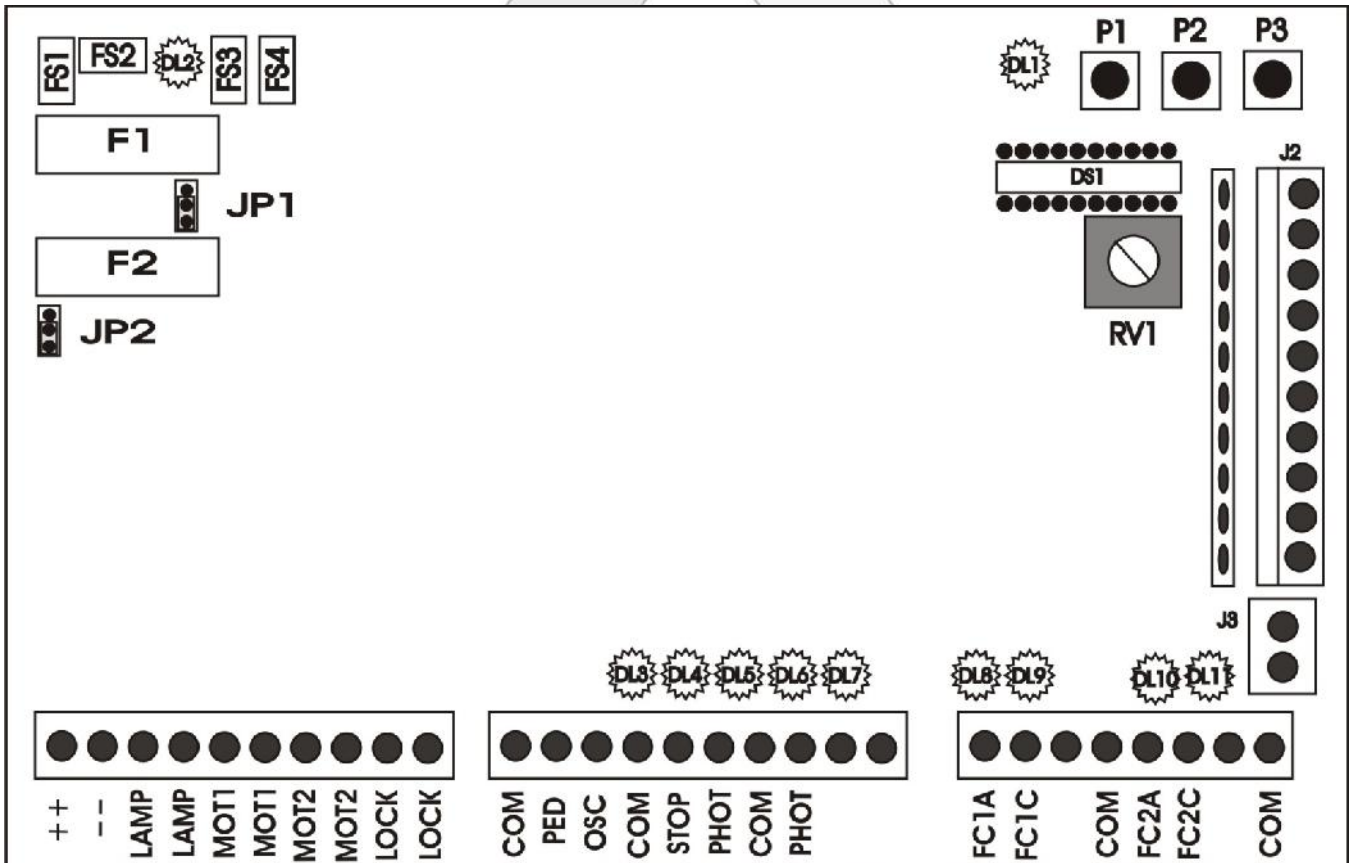

↑ ↑ ↑ THREE LOOPS REQUIRED FOR INITIAL PROGRAMMING

BOARD INTERFACE

COMPONENTS

FS1-2	Battery charge plug 12-24 Vdc
FS3-4	Power supply input 12-20 Vac
F1	Battery Fuse 10A Fast
F2	Output Fuse 2A Slow
JP1	Battery Charge Selector 12/24Vdc
JP2	Output Selector 12/24Vdc
DL1	Programming LED
DL2	Power Supply LED
DL3 DL4	Open Input LED
DL5 DL6 DL7	Stop & Photo LED
DL8 DL9	Motor1 Limit Switch LED
DL10 DL11	Motor2 Limit Switch LED
J3	Antenna Connector
J2	External receiver connector
RV1	Slowing speed regulator
DS1	Setting Up Dip Switches
P1	Radio code programming button
P2	Working time programming button
P3	Pause time programming button

TERMINALS - LEFT TO RIGHT

12Vdc/24Vac	Choose via jumper JP2 Pos 1&2 = 12V
LAMP	Flashing light output
MOT1	Output for motor 1 10A Max
MOT2	Output for motor 2 10A Max
LOCK	Output for electric lock 12Vdc 1A
COM	Common for open inputs PED & OSC
PED	Pedestrian open input (NO)
START	Open/Stop/Close input (NO)
COM	Common for STOP & PHOTO inputs
STOP	Stop input (NC)
PHOTO	Photocell Input (NC)
COM	Photocell 2 common
PHOTO	Photocell 2 Input (NC)
FC1A	Limit switch 1 opening input (NC)
FC1C	Limit switch 1 closing input (NC)
COM	Common for limit switch 1
FC2A	Limit switch 2 opening input (NC)
FC2C	Limit switch 2 closing input (NC)
COM	Common for limit switch 2

CONNECTING THE GEAR MOTORS TO THE LOGIC CONTROLLER

Each gear motor comes with a flexible electrical lead attached with two cores, negative and positive. This lead needs to be connected to motor 2 output (MOT2), and in the case of dual gates also motor 1 output (MOT1) in the control board. NB: Motor 2 is used for single gate installations and in the case of double gates is the gate you may wish to attach an electric lock to as it opens first and closes last. If the control board is positioned close enough it may be possible to connect one motor directly to the control board without joining and/or extending the cable using a suitable cable gland to enter the control board enclosure. In most cases it will be necessary to install electrical conduits and junction boxes to join and extend your motor cables using suitable two core cable. Your Automatic Solutions store can provide the cable or a good local source is generally the large automotive accessory stores as most motor vehicles run 12 and 24 volt systems. We recommend 5mm low voltage cable. No cable run should exceed 10 metres without planning for voltage drop. Ensure all joins are protected from the weather using suitable junction boxes, conduits are adequately clamped and cables are tied to avoid dragging or catching.

Once you have run your motor cables you should have two cores, or in the case of dual gates four cores inside your logic control enclosure and the obvious question is which wire goes into the left terminal and which goes into the right terminal of the motor outputs. There is no easy way of knowing and the answer is it does not matter, we will find out in the next stage and make changes as required then. Make sure you have no power connected to the control board and you can now connect your motor/s to the outputs (MOT2 and/or MOT1) paying attention to which motor will be motor 2 which will open first if so programmed when dual gates overlap. With single gates use motor 2 output only.

INSTALL YOUR INPUT LOOPS

The only other wiring needed before testing your installation is to install a few loops into the “NC” or normally closed inputs. Cut a three short lengths (50mm) of single core cable and strip the two ends. Connect one end to the “photo” terminals and one end to the “com” terminal. Do the same with the “stop” terminal and the “com”. These will need to be removed later if you add safety beams (photocells) or a stop button to your installation but for now will close the inputs and make the board operational.

Note: Although we have stated above that we need to install loops into the normally closed inputs and you may note that the limit switch inputs are normally closed it is not necessary to install loops into these inputs. The board tests these inputs for the presence of limit switches and excludes them automatically when they are not found.

FIT AN ANTENNA WIRE

If you intend using a full antenna, install this now into the antenna terminals taking care not to allow the shield to make any contact with the core of your coaxial. Otherwise cut a small length (150mm) of light cable and strip one end. Place the stripped end into the right hand antenna terminal and secure.

SET YOUR DIP SWITCHES AND JUMPERS

Set your dip switches as per the settings below.

Single Gate Initial Settings										
ON			3				7			10
OFF	1	2		4	5	6		8	9	

Double Gate Initial Settings										
ON							7			10
OFF	1	2	3	4	5	6		8	9	

Ensure that jumper “JP1” the clip is installed to cover the 12 Volt pins and the same thing on jumper “JP2”.

CONNECT BATTERY

If you are using backup battery you will need to make two leads with male spade connectors at each end and connect your battery to FS1 and FS2 on the board. Pay attention to polarity – positive to positive and negative to negative.

CONNECT POWER

You can now plug your logic control board into the 240 volt power outlet or have your electrician connect your power via a suitably installed isolation switch and turn your power on.

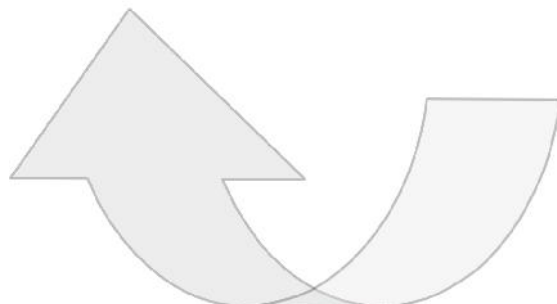

PROGRAM YOUR TRANSMITTERS (REMOTES)

To proceed to the next step you need to have programmed a remote control transmitter into the control board. To program a transmitter press "P1" once on the control board and wait for the led "DL1" to light. Press the button (channel) on your remote control transmitter that you wish to use for two seconds and release. Your transmitter should now be programmed. Repeat for other transmitters. You can also program a second button (channel) on any transmitter to open in pedestrian mode. To program a transmitter to pedestrian opening press "P1" twice and release (NB: Each press of P1 should be spaced by 1 second minimum), when "DL1" is lit press the button (channel) you wish to use for pedestrian access. Up to 50 codes may be stored in any combination of full open or pedestrian open. To erase all codes press and hold "P1" until the red LED "DL1" goes out (about 10 seconds)

IMPORTANT - (If you are not using transmitters you will need to connect a normally open momentary pushbutton into "COM" and "START" terminals to proceed)

CHECK FOR CORRECT MOTOR DIRECTION

This is where you find out if you were lucky enough to have got your motor output wiring in the correct terminals. With your gear motor/s in manual position them about half way open and lock them into automatic mode. Using the transmitter you programmed press the button and release. Because this is the first activation after a power interruption your gates should open. Press your transmitter again to stop the gates. To correct any leaf which did not open simply turn off the power, disconnect the battery lead and reverse the motor terminals. Apply power and test again.

PROGRAM THE CONTROL BOARD

OPTION 1 - Automatic setting of the work times.

Use your transmitter and drive the gate/s to the fully open position. Set the trimmer RV1 to about half way. Press push button "P2" once for a few seconds until "DL1" lights and release. After a few seconds the logic control will make some tests, and then it will self learn the working time by closing the gate. The board will automatically exit this mode when complete and led "DL1" will go out. Use your transmitter (or pushbutton) to test your installation.

OPTION 2 - Manual setting of the work times.

Use your transmitter and drive the gate/s to the fully closed position. Set the trimmer RV1 to about half way. Press push button "P2" once and hold until "DL1" goes out (approx 10 seconds). After a few seconds the gate/s start opening at a reduced speed. During this phase use trimmer "RV1" to obtain the desired slow down speed. When the gate reaches fully open press "P2" and release. Wait a few seconds for "DL1" to light. Next press "P2" and release as follows to register the following steps.

Dual Gates (With Delay)

Press 1 – Motor 1 Start
Press 2 – Motor 2 Start (delayed)
Press 3 – Motor 1 Slow down start
Press 4 – Motor 2 Slow down start
Press 5 – Motor 1 Stop (Wait 5 seconds after hitting travel stop)
Press 6 – Motor 2 Stop (Wait 5 seconds after hitting travel stop)

Single Gates or Dual Gates – No delay

Press 1 – Motor 2 Start
Press 2 – Motor 2 Slow down start
Press 3 – Motor 2 Stop (Wait 5 seconds after hitting travel stop)

The board will automatically exit this mode when complete and led "DL1" will go out. Use your transmitter (or pushbutton) to test your installation.

Setting the pause time

Press push-button P3 until the led DL1 lights. Let the desired pause time pass, and then press push-button P3 again.

END OF SIMPLE SETUP

If all went well you have finished simple setup. On the following pages you will find some more detailed information and wiring diagrams to enhance and add to your installation.

ADVANCED PROGRAMMING, ADDING TO AND IMPROVING YOUR INSTALLATION

DEFINITIONS OF SAFETY INPUTS

Stop

Input connected to a push-button or switch placed outside the unit. It is employed to cause the gate's immediate stop. This control is used in an emergency situation.

Photo-cell

Input connected to an optical barrier. It detects and signals the passage of persons or vehicles in the area crossed by the gate or in the nearby area.

Photostop

Input connected to an optical barrier. It detects and signals the passage of persons or vehicles in the area crossed by the gate or in the nearby area.

Opening Limit Switch

Input connected to a switch placed outside the unit. The switch operates when the gate has completed its opening phase.

Closing Limit Switch

Input connected to a switch placed outside the unit. The switch operates when the gate has completed its closing phase.

DEFINITIONS OF OUTPUTS

Blinker

Lamp's on/off control. The lamp functions as a warning and optical signaller of potential danger for the gate's motion.

Motor 1

Outputs for the opening/closure control of the motor which drives the first gate wing during the closing phase.

Motor 2

Outputs for the opening/closure control of the motor which drives the gate wing delayed during the closing phase. This wing can be connected with an electric lock.

Electric lock

Impulse control for the electric lock release. The output can also control an open gate signalling lamp.

DEFINITIONS OF POWER SUPPLY INPUTS / OUTPUTS

AC IN (FS3 - FS4)

12Vac input for the electronic board power supply.

12Vdc OUT (Pay attention to the position of the Jumper JP1)

Power supply output for the photo-cells and/or any other accessory devices.

BATT IN (FS1 - FS2)

Input for a 12Vdc backup battery connection.

Attention: Set up the jumper JP2 in the right position in order to avoid damages of the equipment and/or battery.

DEFINITION OF ACCESSORY INPUTS / OUTPUTS

Antenna

Input for the connection of an antenna. This input can only be used if a radio receiver card is connected to the unit.

2nd radio channel

Auxiliary control output. To be used only if a two-channel radio receiver card is connected to the unit (J6 connector).

DEFINITION OF OPTICAL SIGNALS

DL1 – Programming led (red)

It is lit in the programming phase and during the gate's motion.

DL2 – Mains power led (green)

It is lit when the 12Vac voltage is present to the AC IN input.

DL3 – Pedestrian start led (green)

It is lit when the pedestrian start control is operated.

DL4 – Start led (green)

It is lit when the start control is operated.

DL5 – Stop led (red)

It signals the gate's block state. The led goes off when the stop control is operated (emergency).

DL6 – Photo-cell led (yellow)

It signals the optical barrier's state. The led goes off when the photo-cell is covered by persons or vehicles

DL7 – Photostop led (yellow)

It signals the optical barrier's state. The led goes off when the photo-cell is covered by persons or vehicles.

DL8 - Opening limit switch led (yellow)

It signals the opening limit switch state for Motor 1. The led goes off when the opening limit switch is operated.

DL9 - Closing limit switch led (yellow)

It signals the closing limit switch state for Motor 1. The led goes off when the closing limit switch is operated.

DL10 - Opening limit switch led (yellow)

It signals the opening limit switch state for Motor 2. The led goes off when the opening limit switch is operated.

DL11 - Closing limit switch led (yellow)

It signals the closing limit switch state for Motor 2. The led goes off when the closing limit switch is operated.

DEFINITION OF TRIMMERS

RV1 – Slow-down speed

It defines the gate's speed during the slow-down phase.

DEFINITIONS OF PROGRAMMING KEYS

P1 - Allows to insert/cancel the radio-command codes in the memory

P2 - Allows to set the motors' work time and the M2 motor's closing delay time

P3 - Allows to set the pause time

DEFINITIONS OF PROTECTION FUSES

F2 – Battery fuse (10A - Fast)

It disconnects the backup battery from the electronic card in case of short-circuit or electric current consumption anomalies.

F1 – Services fuse (1A - Slow)

It protects the electronic unit in case of short circuits or overcurrents on photo-cells or any other accessory devices connected to the card.

DEFINITION OF DIP SWITCH SETTINGS

“Step-by-step Mode” (Dip switches 1 and 2 OFF) – In step-by-step mode a single command via transmitter or a momentary switch connected to the OSC input will cause the gate to open. If no other command is issued and at the end of the slow down phase the gate will stop, the operating cycle is complete and the gate waits for a further command to close. If a command is made before the end of any opening or closing cycle the gate will stop. A new command will cause the reversal of the motion.

“Automatic Mode” (Dip switch 1 OFF and dip switch 2 ON) - In automatic mode a single command via transmitter or a momentary switch connected to the OSC input will cause the gate to open. If no other command is issued and at the end of the slow down phase the gate will stop, the pause period starts and when concluded the gate closes automatically. When the gate is closed the operating cycle is complete and the gate waits for a further command. If a command is made before the end of any part of the opening or closing cycle the gate will stop. A new command will cause the reversal of the motion. If a command is made during the pause part of the cycle the gate will not close automatically and the gate will wait for a new command to close the gate.

“Apartment Mode” (Dip switch 1 ON and dip switch 2 OFF) – In apartment mode a single command via transmitter or a momentary switch connected to the OSC input will cause the gate to open. At the end of the slow down phase the gate will stop, the pause period starts and when concluded the gate closes automatically. When the gate is closed the operating cycle is complete and the gate waits for a further command. If a command is made during the opening phase it has no effect. If a command is made during the closing phase the gate will stop, pause for approximately 1.5 seconds and reopen. If a command is made during the pause part of the cycle the pause time will reset and gate closing will commence later. **IMPORTANT:** If using a time clock to control the gate then apartment mode must be selected.

“Single Wing Mode” (Dip switch 3 ON) – In single wing mode the board drives motor 2 output only (MOT2).

“Kickback / Extra Push” (Dip switch 4 ON) – If an electric lock is fitted it may be necessary to have a brief “kickback” to release in the opening phase or “Extra Push” to lock in the closing phase.

“Wing Delay Zero” (Dip switch 5 ON) – If you have dual gates which do not overlap and do not have an electric lock then it may be desirable to have both gates open and close at the same time and with no delay. Turning on dip switch 5 to achieve this. NB: If dip 5 is on then dip three must be off.

“Lock Output As Open Light” (Dip switch 6 ON) – It is possible to use the lock output as an open light if no lock is used. Turn dip switch 6 on and the lock output can be used to turn on a light.

“Exclude Photocell Test” (Dip switch 7 ON) – The board tests the photocell/s to ensure correct operation and presence of power before every cycle. To disable this test turn dip switch 7 on. If you do not have photocells turn dip switch 7 on.

“Slow Ampstop Motor 1” (Dip switch 8 ON) – The control board will stop the gate should it hit an obstacle causing the motor to work harder and therefore increase the amp draw on the board. The factory default is if the increased amp draw occurs for 0.4 of a second. By turning on dip switch 8 this will increase to 1 second.

“Slow Ampstop Motor 2” (Dip switch 9 ON) – The control board will stop the gate should it hit an obstacle causing the motor to work harder and therefore increase the amp draw on the board. The factory default is if the increased amp draw occurs for 0.4 of a second. By turning on dip switch 9 this will increase to 1 second.

“Turn On Signal LED’s” (Dip switch 10 ON) – It is possible to turn all on board LED’s on or off. In a solar installation turn dip switch 10 OFF after programming to conserve power.

TECHNICAL FEATURES

Power supply

The electric power is supplied to the electronic card and the motors by means of an electric transformer fitted with a protection fuse. The appliance may be connected to an optional backup battery (12Vdc/ 7 Ah) for the automation system to work in case of absence of mains power supply.

Radio Receiver

The electronic unit contains a two-channel radio receiver allowing remote control of the gate by means of the radio transmitter. The radio receiver channel 1 acts as **Start** control and channel 2 acts as **Pedestrian start**. The radio receiver operates with a self-learning logic and can store up to 50 different codes from the remote controls. Each code may be addressed on the desired channel (start or pedestrian start). The memory content is preserved in absence of power supply. The memory contents may be erased (total cancellation). In alternative the electronic unit is equipped for the optional connection of an accessory radio receiver card (J6 connector). The channel 1 of the radio receiver card ends with a non-polarized electric contact (relay) directly connected to the **start** input. The channel 2 of the radio receiver card ends with a non-polarized electric contact (relay) directly connected to the **2nd radio channel** output.

Work Time

The motors' work time is controlled by two independent digital timers. If any command interrupts the wing's travel before its end, the timer stops and the elapsed time is stored in memory. Therefore the unit can determine, with a fair approximation, the partial working time necessary for the wing to end its travel. For the automation system to work properly the work time value to be set must be slightly (approx. 5 sec.) above the wing's actual work time. In this way the motor will stop even if the limit switch control has not operated. We recommend to adjust the work time so that the wing starts to slow down at min. 50 cm. from the end of its travel. The stop of the wing depends by the current consumed by the motor (Torque). During the normal speed phase, when the motor's current reaches the self-learned value, the gate stops (both wings) in opening and then it reverses its motion for approx. 2 sec., while during the closure phase, the gate stops and reverses its motion after approx. 1.5 sec. After the electric power is supplied to the electronic card (at installation), or after one absence of power supply, when the Start push-button is pressed for the first time the gate performs an opening cycle.

Warning: In case of absence of power supply the position of the gates will be lost (Timers reset) and the gates first command will perform an opening manoeuvre.

Kickback / Extra-push

This procedure can be enabled or excluded. It is usually employed to help the electric lock insertion and release during bad weather conditions (wind, etc.). The "**kickback**" procedure consists of a logic sequence operating the electric lock with a short closure phase (approx 1 sec.) with the gate closed. The electric lock is released only after the wing has started its opening motion. The "**extra-push**" procedure is enabled only during the closing slow-down phase near at the end of the wings' travel. It consists of a short acceleration of both wings (approx. 1 sec.) to help the electric lock's insertion.

M1 delay at opening

The unit causes a fixed delay of approx. 2 seconds between the first wing's (M2) and the second wing's (M1) start during the gate's opening phase. This delay is imposed irrespective of the position from which the gate starts to open. This delay may be cancelled by setting the **dip switch 5 =ON**.

Blinker

The electronic card supplies an on/off control (flashing light) to the lamp. The logic of the blinking allows displaying the gate's operating.

Quick flashing light: signals the opening phase

Slow flashing light: signals the closing phase

Fixed light: signals that the gate is blocked in wait that the obstacle that covers the photocell or photostop to be removed.

The device supplies an on/off control (flashing light) to the lamp for approx. 1 sec. before the motors start (pre-alarm).

Important: In case of absence of power supply, with the backup Battery connected to the card, the blinker flashes every 4 sec. (in opening and closing cycle).

OPERATION MODES

Introduction

The electronic unit contains a micro-processor to control the gate's operation modes. These are the four main operation phases:

Phase preceding the gate's motion

Gate's fast motion phase

Gate's slow motion phase

Gate's pause phase (open gate)

The unit can function in three modes:

Step by step – This mode is enabled by setting the dip switches 1=OFF 2=OFF

Automatic – This mode is enabled by setting the dip switches 1=OFF 2=ON

Apartment– This mode is enabled by setting the dip switches 1=ON 2= No effect

Notice: The operation logic setting (dip switch), the work time programming and the pause time programming must be carried out only if the cycle is concluded or before it starts (with closed gate).

The opening and closure cycles are enabled by a **Start** or **Pedestrian start** control.

Important: Whatever logic has been selected, the first Start command after the power is supplied to the electronic card will always cause the start of an opening cycle.

“Step-by-step” mode

After the power is supplied to the electronic card the first start command determines an opening cycle. During the slow-down phase, at the end of the two work times or after the Limit switches have operated for both motors, the gate stops. The operating cycle is completed and the system waits for a new start command to determine the closing cycle. If a start command is supplied when the end of travel has not been reached yet the gate stops. A new start command will cause the reversal of the motion.

“Automatic” mode

After the power is supplied to the electronic card the first start command determines an opening cycle. During the slow-down phase, at the end of the two work times or after the Limit switches have operated for both motors, the gate stops. The pause period starts. At the end of the pause period the gate closes automatically. The operating cycle is complete only when the closing motion has ended. If a start command is supplied before the end of travel is reached the gate stops. A new start command will cause the gate to reverse its motion. If a start command is supplied during the pause period the operating cycle is interrupted and the gate does not close automatically. A further start command will determine a closing cycle.

“Apartment” mode

After the power is supplied to the electronic card the first start command determines an opening cycle. During the slow-down phase, at the end of the two work times or after the Limit switches have operated for both motors, the gate stops. The pause period starts. At the end of the pause period the gate closes automatically. The operating cycle is complete only when the closing motion has ended. If a start command is supplied while the gate opens, the command will have no effect. If a start command is supplied while the gate closes, the gate will stop and reverse its motion after approx.1.5 sec. If a start command is supplied during the pause period, the period will be reset and the automatic closure will start later.

Important: If the gate opening is controlled by a clock the “apartment” mode must be enabled.

“Single wing” mode

This mode is employed with single-wing gates. When enabled, it drives the motor M2 only. The operating modes described above remain unchanged. When the “single-wing” mode is selected the **dip switch 3=ON** must be set.

Note: At the beginning of each opening cycle, with the gate closed, the electric lock can operate in 2 modes:

1) If dip switch 4=OFF the electric lock operates a split of second (0,8 sec) before the first wing (M2) starts , and stops operating 2 seconds after the wing's start.

2) if dip switch 4=ON the electric lock operates for a short time (approx.1 sec.) closing the wing, and stops operating 2 seconds after the M2 wing starts the opening. The **“kickback”** procedure is usually employed to help the electric lock's release during bad weather.

In any operation mode, the safety devices cause the following effects:

Stop: If the stop command is enabled no cycles can start and the start command will have no effect. If a stop command is supplied during motion, the gate will immediately stop and interrupt its operating cycle. This condition will continue while the stop command is on. A start command following a stop command always determines an opening cycle. A stop command supplied during the pause period interrupts the operating cycle. A start command subsequently supplied will start a closure cycle.

Photo-Cell: This device has effect only during the closure phase or in the pause period. If an obstacle covers the photo-cell during the closure phase, the gate stops and reverses its motion after approx. 1.5 sec. If an obstacle covers the photo-cell during the pause period the pause time is reset and the automatic closure is therefore delayed.

Photostop: If an obstacle covers the photo-cell during the gate's motion (opening or closure), or during the period preceding the operating cycle's start, then the gate is temporarily stopped, until the obstacle is removed. When the obstacle is removed and the photocell is freed, an opening cycle will start. This does not apply when a start command determines the closing phase in step-by-step mode at the end of an opening cycle. If an obstacle covers the photostop during the pause period the pause time is reset and the automatic closure is therefore delayed.

Pedestrian start: The pedestrian start command operates in the same way as the other start command, but in this case only the (M2) wing fitted with the electric lock will be opened or closed. The pedestrian start command has no effect during a start cycle and up to the end of the closing phase (closed gate). During a pedestrian start cycle the start command is always active and causes the start of an opening cycle for both wings.

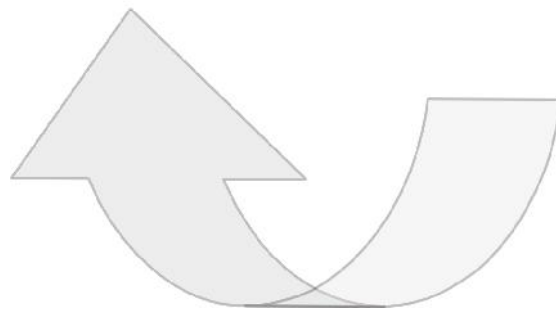

ELECTRICAL AND MECHANICAL SPECIFICATIONS

Dimensions and weight (with plastic box): 186 x 283 x 112 mm – 2.3 Kg

Power supply transformer: 230/12-15-20 Vac - 100VA

Battery-charger capacity: 0.5 A max

Optional battery capacity: 12/24 Vdc – 7 Ah

Blinker power supply: 12/24 Vdc - 15W max

Relays contacts capacity: 20 A max

Electric lock power supply: 12/24 Vdc - 15W max

Motor power supply: 12/24 Vdc - 100W max (total)

Radio receiver power supply (J6): 12 Vdc - 2W max

Accessories power supply: 13,5Vdc or 24Vdc - 3W max

Operating temperature range: 0 to + 60 °C (internal)

2nd radio channel relay contact characteristic: 24 Vac – 0.5 A max

Motors' work time: programmable, 1 to 120 sec.

Pause time: programmable, 1 to 120 sec.

2nd wing closing delay: programmable, 0 to 120 sec.

Amperometric Stop: Automatic

Caution: The unit must be not switched on if the connected loads or the power supply exceed the limits. Failure to observe this precaution can result in damage to persons, animals or objects for which the manufacturer cannot be held responsible.

ELECTRICAL CONNECTIONS

7 electric connectors are fitted to the card:

- 1) **J2** 10-pole removable terminal board for the connection of the commands and safety devices
- 2) **J6** 10-pole connector for the optional connection of a radio receiver card
- 3) **J5** 2-pole Terminal board for the connection of the aerial cable
- 4) **J1** 10-pole removable terminal board for the connection of the power devices
- 5) **J3** 8-pole removable terminal board for the connection of the limit switches and/or Encoder
- 6) **FS1,FS2** nr. 2 Faston terminals for the connection of a Backup battery
- 7) **FS3,FS4** nr. 2 Faston terminals for connection of the power supply transformer

Terminal board J2

Terminal1 - Common terminal for all electric contacts of commands

Terminal2 - Pedestrian start push-button's normally open electric contact

Terminal3 - Start push-button's normally open electric contact

Terminal4 - Common terminal for all electric contacts of stop push-button and photo-cell

Terminal5 - Emergency push-button's normally closed electric contact (stop)

Terminal6 - Photo-cell's normally closed electric contact

Terminal7 - Common terminal for the electric contact of photostop

Terminal8 - Photoelectric cell's normally closed electric contact (photostop)

Terminal9 - 2nd radio-channel's normally open electric contact (output)

Terminal10 - 2nd radio-channel's normally open electric contact (output)

Important: The normally closed inputs not in use must be fitted with jumpers

Connector J6

Terminal1 – Normally open electric contact connected to the start

Terminal2 – Common of the normally open electric contact connected to the start

Terminal3 – Normally open electric contact connected to the 2nd radio-channel output

Terminal4 – Normally open electric contact connected to the 2nd radio-channel output

Terminal5 - Power supply negative (common)

Terminal6 - Power supply positive

Terminal7 - Power supply positive

Terminal8 - Power supply negative (common)

Terminal9 – Aerial input (shield)

Terminal10 – Aerial input (signal)

Terminal board J5

Terminal1 – Aerial cable connection (shield) for radio receiver card
Terminal2 – Aerial cable connection (signal) for radio receiver card

Terminal board J1

Terminal1 - Power supply positive for photo-cells or other devices
Terminal2 - Power supply negative for photo-cells or other devices (common)
Terminal3 - Power supply positive for blinker
Terminal4 - Power supply negative for blinker (common)
Terminal5 - Motor M1 power supply
Terminal6 - Motor M1 power supply
Terminal7 - Motor M2 power supply
Terminal8 - Motor M2 power supply
Terminal9 – Power supply positive for electric lock
Terminal10 – Power supply negative for electric lock (common)

Terminal board J3

Terminal1 - Motor 1 opening Limit switch normally closed electric contact
Terminal2 - Motor 1 closing Limit switch normally closed electric contact
Terminal3 - Motor 1 Encoder signal input
Terminal4 - Common terminal for Motor 1 Limit switches and Encoder
Terminal5 - Motor 2 opening Limit switch normally closed electric contact
Terminal6 - Motor 2 closing Limit switch normally closed electric contact
Terminal7 - Motor 2 Encoder signal input
Terminal8 - Common terminal for Motor 2 Limit switches and Encoder

Important: The equipment only accepts a “TTL” or “OPEN COLLECTOR” input as Encoder signal.



OPEN COLLECTOR

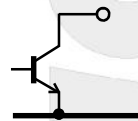

FS1 Faston – Backup battery's positive pole connection
FS2 Faston – Backup battery's negative pole connection

FS3 Faston – 12/15/20 Vac power supply from the electric transformer
FS4 Faston – 12/15/20 Vac power supply from the electric transformer

CTR50 - Connection of the devices

Motor 1 – Terminals 5 and 6 on J1
Motor 2 – Terminals 7 and 8 on J1
Blinker – Terminals 3 and 4 on J1
Electric lock – Terminals 9 and 10 on J1
Photo-cells power supply – Terminals 1 and 2 on J1
NC photo-cell contact – Terminals 4 and 6 on J2
NC stop push-button – Terminals 4 and 5 on J2
NC photostop contact – Terminals 7 and 8 on J2
NO start push-button – Terminals 1 and 3 on J2
NO pedestrian start push-button – Terminals 1 and 2 on J2
Aerial – Terminals 1 and 2 on J5
Open gate lamp - Terminals 9 e 10 on J1
NC Motor 1 opening limit switch contact – Terminals 1 and 4 on J3
NC Motor 1 closing limit switch contact – Terminals 2 and 4 on J3
NC Motor 2 opening limit switch contact – Terminals 5 and 8 on J3
NC Motor 2 closing limit switch contact – Terminals 6 and 8 on J3
Motor 1 Encoder connection - Terminals 3 and 4 on J3
Motor 2 Encoder connections - Terminals 7 and 8 on J3

IMPORTANT:

If no cable is connected to the FC1A and FC1C inputs, the control of Motor 1 limit switches will be automatically disabled.
If no cable is connected to the FC2A and FC2C inputs, the control of Motor 2 limit switches will be automatically disabled.

CONNECTING A SINGLE SET OF SAFETY BEAMS

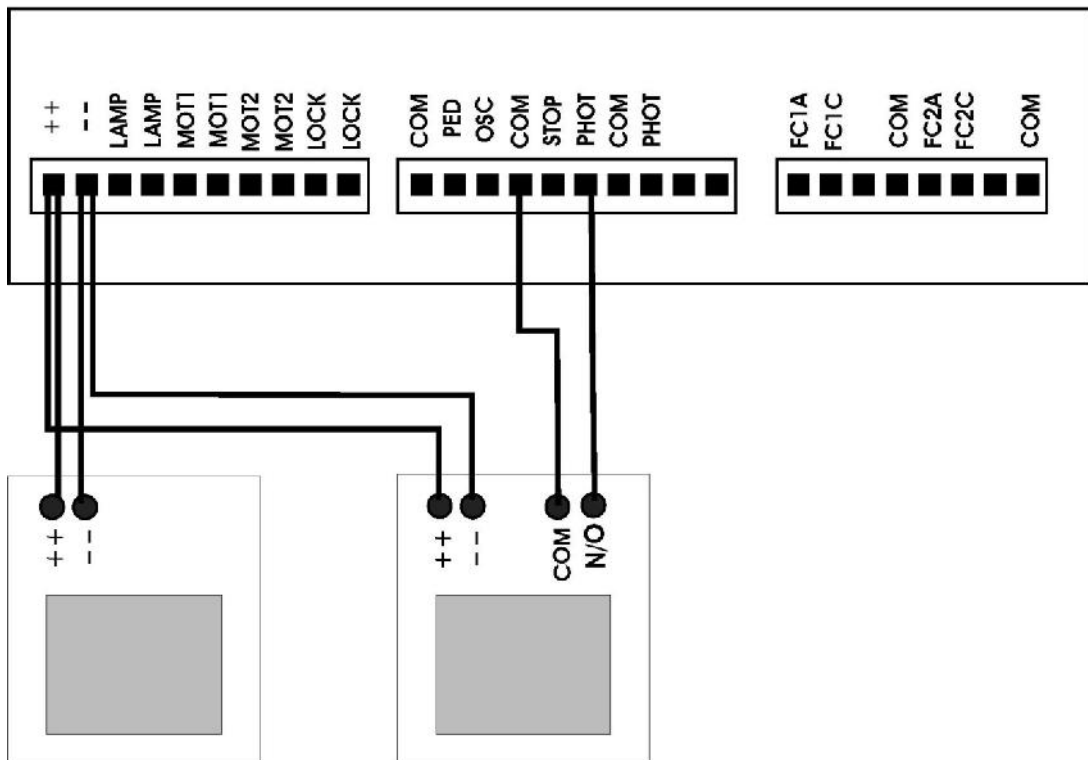

CONNECTING TWO SETS OF SAFETY BEAMS

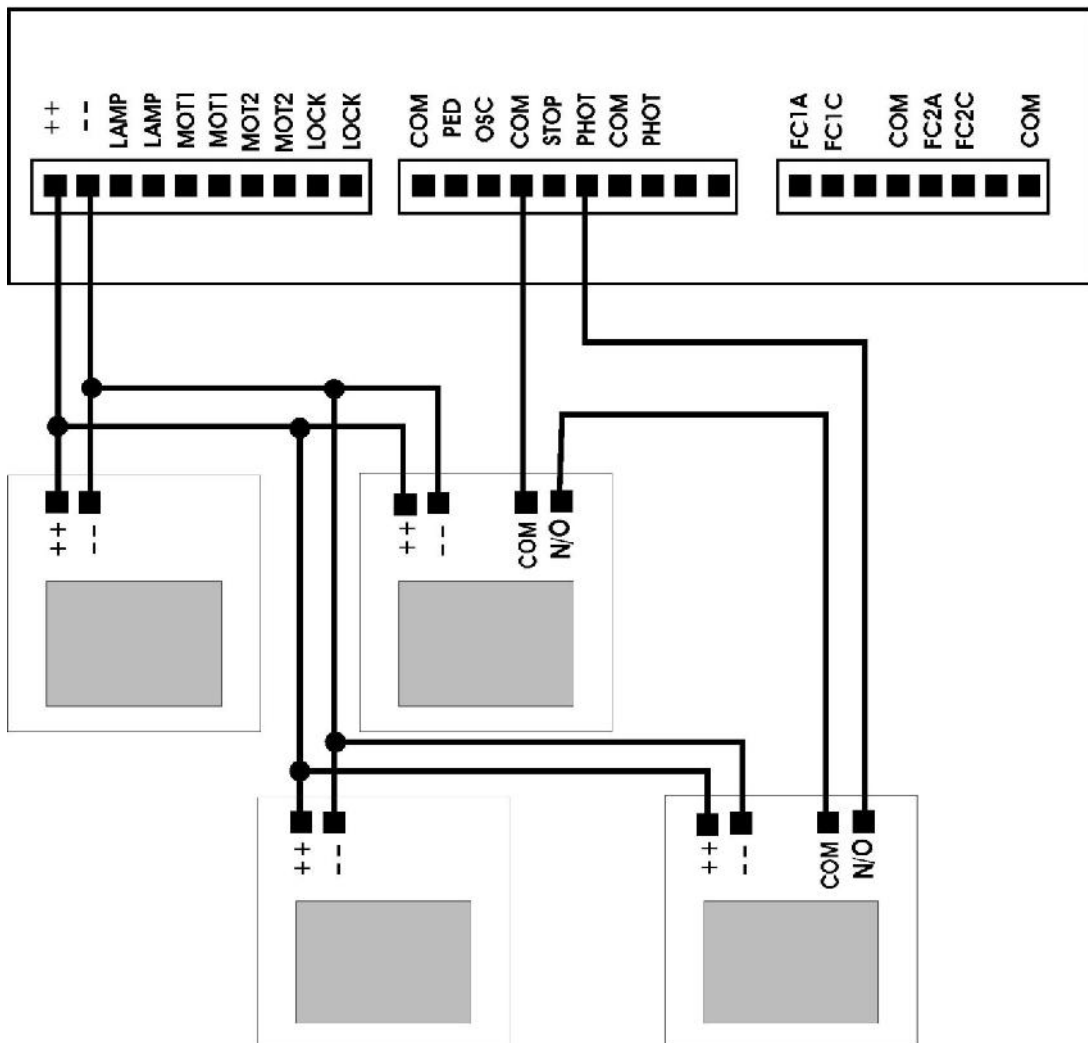

CTR50

General diagram

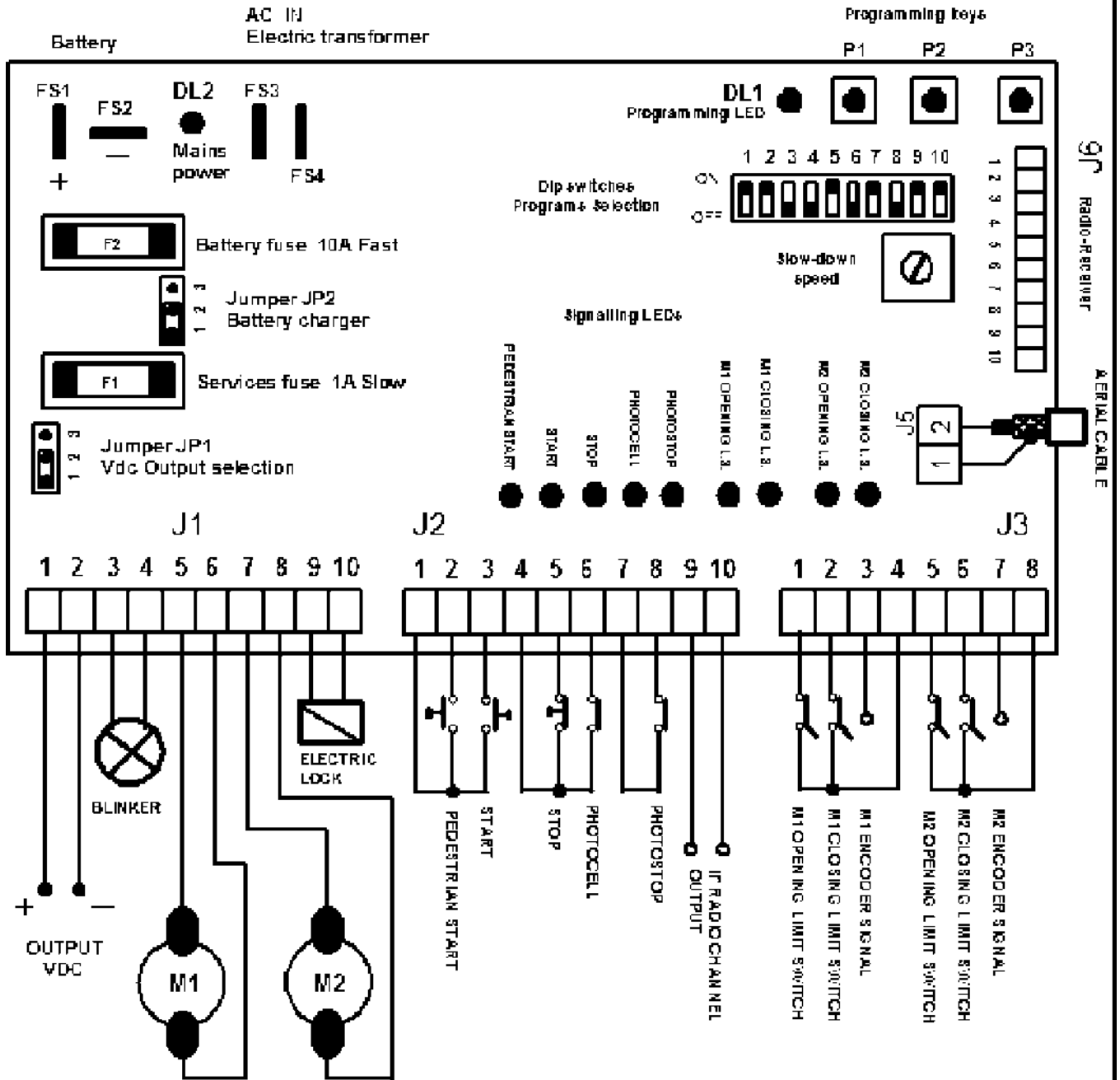

CONFORMITY DECLARATION (To EMC directive EN45014 and ISO guide 22)

Description of the appliance: Electronic board for the control of 1 or 2 low voltage motors for gate automation.

Model: CTR50

Reference rules applied: EN 50081-1, EN 50082-1, EN 55014

Basic rules applied: EN 61000-6-3 + A11 (2004), EN 61000-6-1, EN 301 489-1, EN 301 489-3, EN300 220-2, EN 300 220-1

Test laboratory: NEMKO SPA

Outcome: Positive

The manufacturer declares that the above listed products comply to the norms on electromagnetic compatibility provided for by directives 89/336/EEC, 92/31/EEC, 93/68/EEC.

Date: 24-08-2007

AUTOMATIC SOLUTIONS AUSTRALIA PTY LTD
PO BOX 1034 CANNING VALE WESTERN AUSTRALIA 6970
TECHNICAL HELP – service@automaticsolutions.com.au

SELF INSTALL - NEED TECHNICAL ASSISTANCE?

OPTION 1: DIRECT WITH THE SERVICE DESK – QUICKEST AND MOST EFFECTIVE METHOD

Submit your enquiry direct with the service desk at – service@automaticsolutions.com.au

The service desk has the most experienced staff in Australia to help with your problem but they need your help.

- Describe your problem in detail and as clearly as possible. Don't forget to include a telephone number.
- Be certain to detail which model or models of you are working with.
- Send photos of the installation – they love photos. The people at the service desk are good but they are even better when they can see the installation. Send photos of the overall scene so they can see the entire installation. Also send photos of the wiring to the control board and any other part of the installation you think is relevant.
- Send video if appropriate. Smartphone's these days take remarkably good video in small file sizes which can be emailed in a moment. If your problem needs a video to show the issue please feel free to send it.

**NOTE: THIS IS BY FAR THE FASTEST AND MOST SUCCESSFUL WAY TO SOLVE YOUR PROBLEM
PHOTOS AND VIDEOS ARE THE NEXT BEST THING TO BEING THERE**

OPTION 2: LODGE YOUR ENQUIRY LOCALLY - SLOWER BUT CAN STILL BE EFFECTIVE

Make contact with the store of purchase. Branch staffs are typically not technicians and dependent on their length of service will have varying degrees of technical knowledge. If they cannot help however they will certainly either source help locally from their technicians or make contact with the service technicians on your behalf.

OPTION 3: SERVICE CALL WITH AUTOMATIC SOLUTIONS TECHNICIAN – SLOWEST METHOD

If you fall within the local branch service area it may be possible to book a local technician to look at your installation. Wait times will vary dependent on local workloads. The cost is a service fee which includes the first half hour and the hourly rate thereafter. If any Automatic Solutions provided parts are found to be defective and within warranty these will be provided free of charge.

(NOTE: If you suspect that any parts are defective and within warranty you may wish to consider option 4)

A note on this option: If you decide on this option you will be asked to sign an "authorisation to proceed" which will provide legal authority and payment security. This form has three options available of which only the first two are available to you. The third option is for warranty repairs only for full install customers. Self install customers requiring warranty only service need to refer to option four below.

IMPORTANT: IN SHORT THIS OPTION WILL INCUR CHARGES

OPTION 4: RETURN THE PRODUCT IF BELIEVED TO BE FAULTY

As a self install customer who has purchased product if you believe the product to be faulty rather than an installation or site problem you have the option of returning the product for evaluation and to exercise your right to a replacement, repair or refund as applicable. All returned product is forwarded immediately to the service technicians for evaluation and response. There are two main methods available to return product –

- Direct to the service centre – this is the quickest method as it cuts out the branch delay
- Via the branch of purchase – slower because of the delay at the branch

When choosing this option you need to complete a product return form. This form gives you all the information on procedure involved and where to send to. These are available at the branch of purchase, can be emailed to you (contact your branch), or available here - <http://automaticsolutions.com.au/page/warranty.php>